

SUMITOMO

P A V E R S

Sumitomo Asphalt Paver
Jpaver
HA60C-8B
HA60W-8B



 **SUMITOMO (S.H.I.)
CONSTRUCTION MACHINERY CO., LTD.**

731-1 Naganumahara-cho, Inage-ku, Chiba, 263-0001 Japan

For further information please contact:

Phone : +81-43-420-1829 Facsimile : +81-43-420-1907

<http://www.sumitomokenki.com/>

We are constantly improving our products and therefore reserve the right to change designs and specifications without notice.
Illustrations may include optional equipment and accessories and may not include all standard equipment.

HA60C-8B
Photo may include optional equipment

TRANSITION TO A NEW STAGE

Paving the way. With our way.

SUMITOMO Pavers are designed under the concept of the following 3 points and manufactured with high quality.

- **Human Friendly**
 - **Eco Friendly**
 - **Repair Friendly**
- High Performance**
Easy Operation
Cost and Time Saving

[Crawler Type]
HA60C-8B
EU Stage III B / EPA Interim Tier 4



[Wheel Type]
HA60W-8B
EU Stage III B / EPA Interim Tier 4



Photo may include optional equipment

High-power torque and low fuel consumption engine

The power system, a combination of an intelligent **ISUZU** engine and **SUMITOMO's** cutting-edge technology, delivers high work efficiency with low fuel consumption.



New Generation Engine System "SPACE 5+"



4JJ1X Engine System Overview

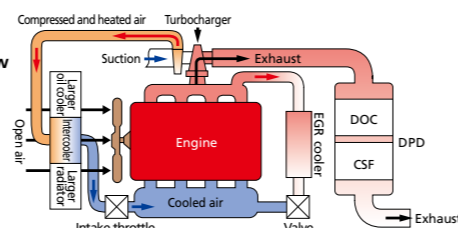

- **NOx 18% Reduction**
(as compared to Tier 3 levels)
- **PM 92% Reduction**
(as compared to Tier 3 levels)

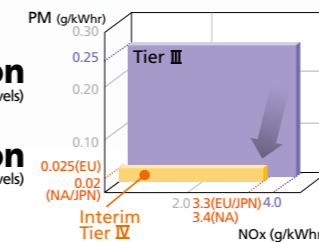

Compliant to Emission Regulations U.S. EPA Tier 4 Interim, EU Stage III B, and JPN Tier 4 Interim

The state-of-the-art engine system "SPACE 5+" substantially reduces NOx (nitrogen oxide) and PM (particulate matter) contained in the exhaust gas, further reducing or minimizing the impact on the environment.

After-Treatment Technology: Diesel Particulate Diffuser (DPD)

DPD is an exhaust after treatment device which traps and burns off PM in the exhaust gas. PM accumulation can be monitored by the DPD status gauge, and Auto Regeneration (filter cleaning) will be conducted at regular intervals.

DPD Structural Overview

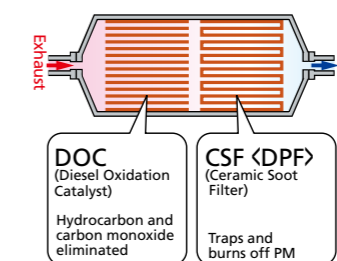

Monitor Display (DPD gauge)



World First: Screed Extensibility Allows a Double Role Save a Maximum of 50% on Working Hours.

The infinitely variable triple screed can be used for 2.3~6.0 m widths

World first

The J-Paver screed can be freely extended from 2.3 m to 6.0 m without any bolt-on extension screed.

STV compaction system

The adjustable "Strike-off" guides the asphalt mixture smoothly under the screed, and the "Tamper" and "Vibrator" achieve strong and even compaction for pavements with smoothly finished surfaces and superior densities.



Photo may include optional equipment

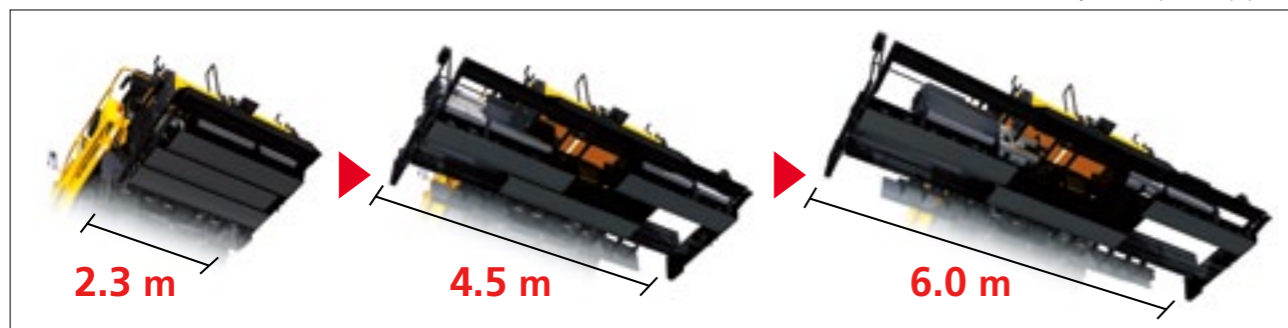

The new J-Paver2360 uses a new frame structure to drastically improve rigidity. As a result, it can carry out consistently stable paving operations.

Double role

The J-Paver2360 covers two conventional screed ranges.

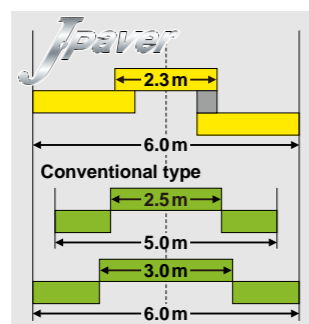

Easy transportation

The HA60C(HA60W) can be completely loaded onto a 2.5 m-wide trailer and start paving without having to assemble the screed.



Photo may include optional equipment

The human friendly

LPG Blower burner (Auto. Temp control type)

The heating controller keeps the temperature of each screed to the setting temp automatically.



Electric heating system (option)

Sumitomo's latest control system delivers ecologically optimized heating without increasing the horsepower of the engine.



Height of extendable screeds

When a difference in surface height occurs between front and rear screeds, it can be adjusted by just a flick of a switch.



Center crown

The slope from center to side can be adjusted by a switch on the hydraulic crown device.

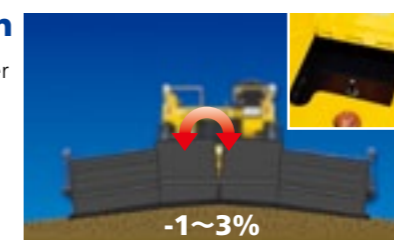

Extendable mold board (Powered type)

The extendable mold board cuts off the material to avoid over capacity in front of the rear screed. And it can carry the material smoothly to the end of screed.

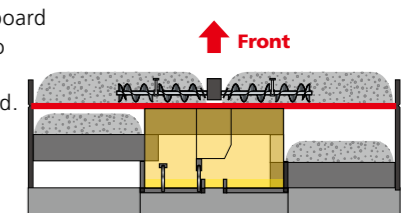

Hydraulic height adjustment

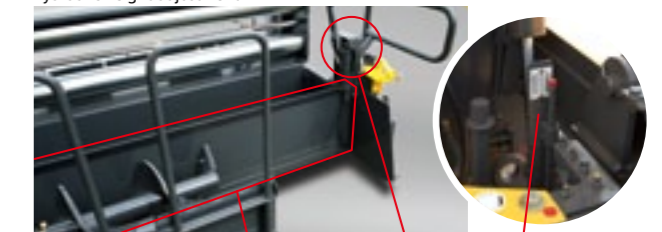

Extendable mold board Hydraulic cylinder Center (manual)

Automatic screed lock

When the automatic lock device is activated, the screed lift cylinder prevents (holds) the screed from sinking into the surface when the machine stops.

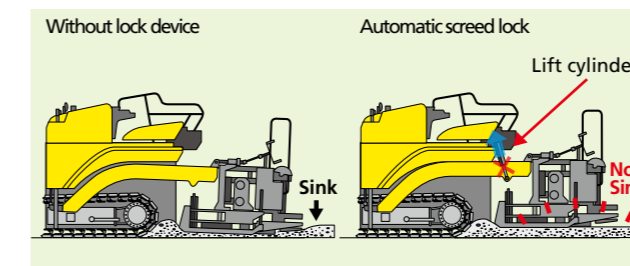

Screed assist

When paving thick layers, the screed lift cylinder assist floating of the screed by the back pressure.

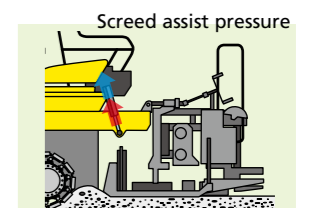

Anti-climb lock (option)

When the anti-climb lock device is activated, and the screed lift cylinder prevents (holds) the screed from floating up to the surface when the machine stops.

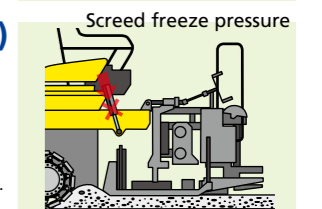

Free: → Pressure: → Lock (hold): ×

Labor-saver Feeding System for Best Efficiency.

Low front and large hopper

The hopper's leading edge is low to suit dump trucks with low bumpers. The hopper also has ample supply capacity.

The hopper front apron is operated by two hydraulic cylinders, which keeps material inside the hopper and prevents it from spilling onto the ground.



Individual operating hopper wings

This function is useful to avoid obstacles on the road. And operation depending on the volume of materials is possible.



Reversible auger conveyor

A perfect balance of materials in front of the screed can be achieved by this function.



Hydraulically adjusted auger

The height of the auger can be adjusted freely according to the paving thickness. (Adjustment range; 115 mm-265 mm *from the bottom of the auger to the ground)



Oscillating push roller

When paving a curved road, the push roller is contacting the tire of the dump truck constantly.



Easy operation and comfort

Movable control box

The control box can be moved from left to right to provide the operator with greater flexibility.

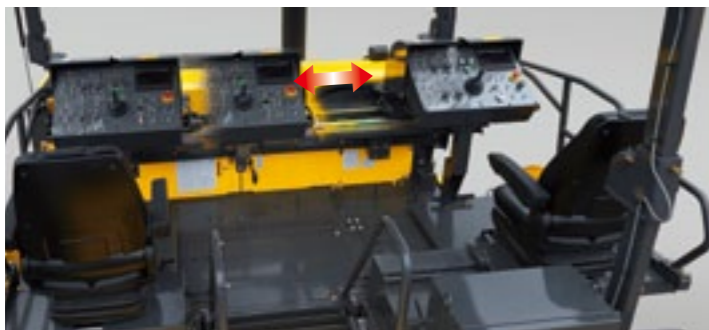

Slide out seat

The slide out seat is useful for checking the road and working conditions. The control box can also slide to suit the seat. The deluxe suspension seat also adds a higher level of comfort.



The user friendly and repair friendly

Color monitor

The liquid crystal color monitor displays useful information and can adjust many functions. These simple toggle switches have been used which allows them to be replaced individually with ease.

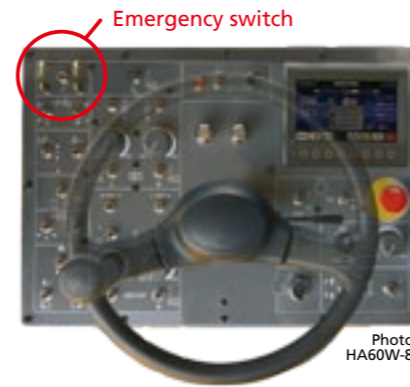

Photo: HA60W-8B



Sub color monitor

Sub color monitor is equipped on both sides of the extendable screed.



Eco Mode switch

The Eco Mode switch drops the engine speed from 2,200 min⁻¹ to 2,000 min⁻¹ under light loads, which is useful for reducing fuel consumption.



Eco Mode switch

Hard top (FPR) canopy

The hard canopy can be folded using the hand pump easily. And the exhaust pipe is folded at the same time.



Folding

Emergency controls

Sumitomo machines are equipped with many emergency control systems. Sumitomo's concept is to continue paving where possible, or in the worst case, move the machine to a safe place away from the road if engine or pump malfunctions.



Self-sealing for hand pump operation also available (optional)

Failure device	Functions					Emergency operation
	Travel		Paving			
	High speed	Low speed	Manual	Auto(sensor)	Heating	
Main panel switch and dial	×	○	○	○	○	Operate by monitor
Main panel controller	×	○	○	○	○	Operate by monitor
1 Machine controller	○	○	○	×	×	Replace controller cable
2 Machine controllers	○	○	×	×	×	Replace controller cable
3 Machine controllers	×	○	×	×	×	Operate by emergency mode (main panel controller)
Engine or Pump	×	×	×	×	×	Retracting and lifting up the screed, and closing hopper by hand pump

Crawler Type for Powerful Towing Capacity and Exceptional Paving Flatness.



Jpaver
HA60C-8B
 EU Stage III B / EPA Interim Tier 4

Adopting the latest travel control system

The engine, hydraulic pumps, and traveling motor are centrally controlled with fine precision by the computer. In addition, settings are stored in the computer's memory, so paving can be carried out simply by turning the traveling switch to "on" or "off". Sumitomo's latest feedback system delivers superior traveling stability (by maintaining the set speed and course).

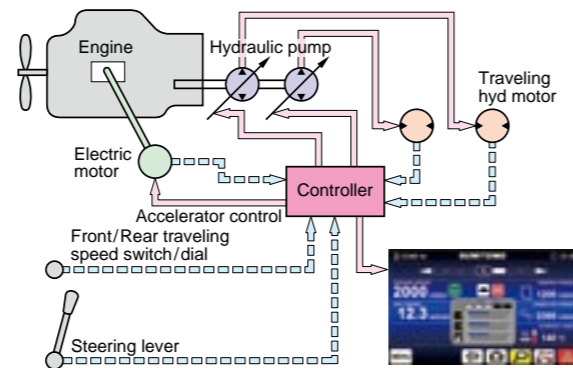
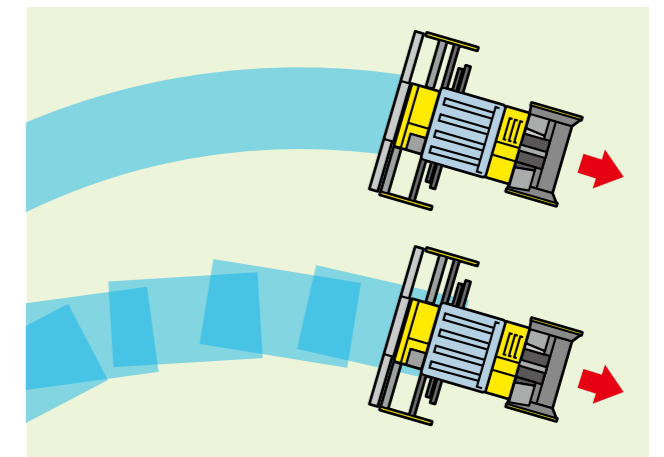

Photo may include optional equipment

Smooth steering with computerized control

The machine is automatically controlled, with left and right side traveling speeds being set to curve in a continuous smooth arc without losing traction force.



Spin-turn function installed

This function makes it possible to turn on the spot, which is very useful on cramped job-sites such as dead ends.

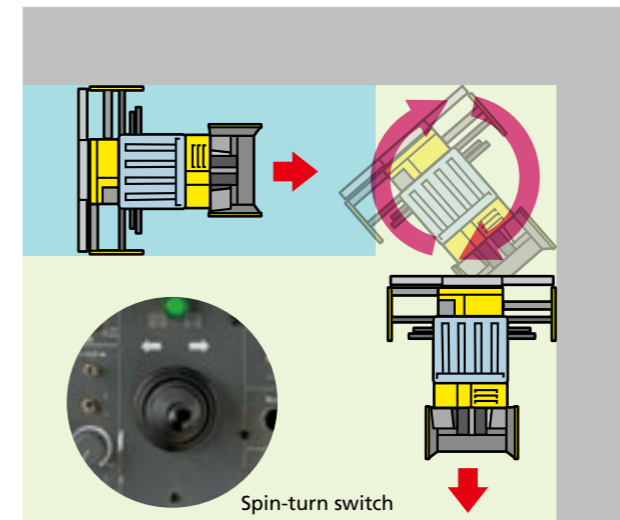

In-shoe motor

The drive motors are mounted inside the shoe and connected directly via sprockets, eliminating chain backlash. This design ensures strong road surface traction capabilities.



Improvements to smoothness attained by superior surface contact

The oscillating bogie absorbs impact from uneven road surfaces, such as those created by manholes.

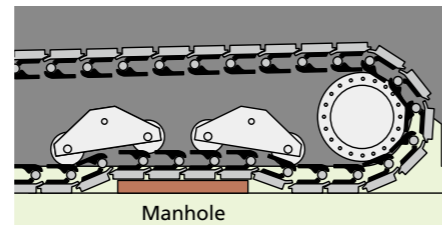

Foldaway retaining plate

Extremely useful for feeding materials outward smoothly. The plate is stowed completely within the machine width.

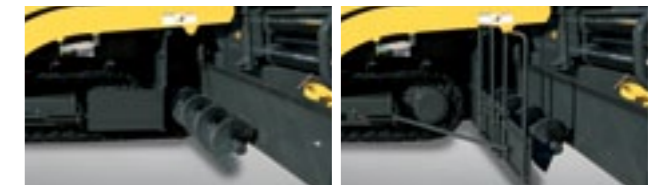

Utilization of a link-shoe with durable rubber pads

The durable rubber pads are equipped on the link-shoe, so asphalt surface is not damaged.



Crawler blade (option)

The crawler blade scrapes off the spilled material in front of the shoe.



Wheeled-type for Great Mobility with Outstanding Drivability.



Jpaver
HA60W-8B
 EU Stage III B / EPA Interim Tier 4

Photo may include optional equipment

The 4WD with parallel drive system makes the front and rear wheels start rotation exactly simultaneously

This system prevents slipping of the front wheel, and makes a smooth starting motion possible. Furthermore, the speed feedback system maintains driving speed without influence of the material load, and powerful traction force is provided while paving.

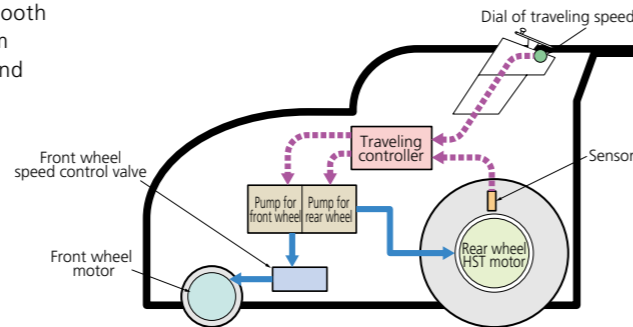

Two modes of travel speed

- **High-speed (0~15 km/h)***
 A mode designed for high-speed travel
 *Forward, backward (0~8 km/h)
- **Low-speed 2WD (1.0~20 m/min)**
 A mode designed for paving speeds which is rear-wheel drive only.
- **Low-speed 4WD (1.0~12 m/min)**
 A mode designed for paving speeds which provides powerful traction force through 4 wheel drive.



Braking steering (option)

The machine can turn with a minimum radius by locking the unilateral rear wheels with brakes.

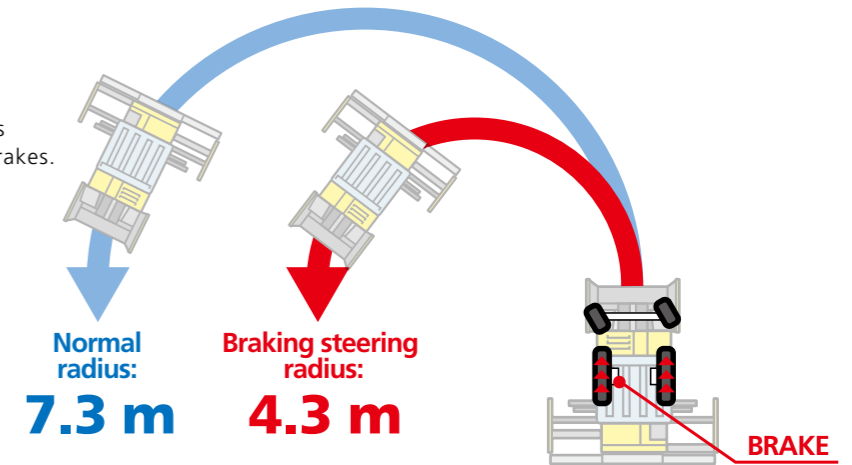

Tires can be changed with the screed arm still attached

If a rear tire is punctured, it can be changed without removing the screed and screed arm.



Tire changing situation

Storage space for the retaining plate in the hopper section

The retaining plates can be stowed in the side of hopper.



In-wheel-motor

The drive motors are mounted inside of the wheel, and eliminate chain backlash. This design ensures strong road surface traction capabilities.



Front wheel traction control

The front wheel traction power (hydraulic pressure) can select from 4 modes depending on the paving conditions.



Extension auger storage

The extension augers can be stowed under the hopper.



Easy maintenance

Daily inspections are extremely straightforward. Oil and grease checks, filter changes as well as other maintenance jobs can be easily carried out just by opening the covers.

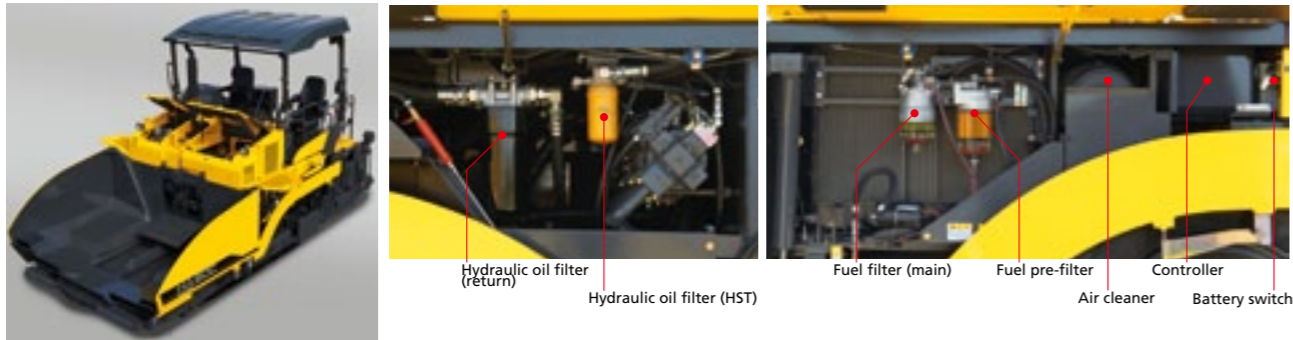

Grade and slope sensor (option)

The grade sensor is used for leveling screed along a height reference. The slope sensor serves to control the cross-slope of the screed.

Material flow sensor (option)

The material flow controller is used for keeping the material volume in front of the screed.



	Sensor type	Feature
①	Contact type grade sensor	For direct tracing of a reference (stringline, ground).
②	Digi-rotary grade sensor	Same as No.1. This can be easily operated by "Digital controller".
③-1	Ultrasonic type grade sensor	Non-contacting tracing of a reference (stringline, ground).
③-2	Big-ski	Three ultrasonic sensors scan the reference in non-contacting operation.
④	Slope sensor	This is used with No.1.
⑤	Digi-slope sensor	This is used with No.2 or No.3. This can be operated by "Digital controller".
⑥	Material flow sensor	This is used for controlling the auger speed (The contact type of the conveyor sensor is standard).

3D-machine control (option)

3D-machine control system makes it possible to automatically control grade and slope according to the digital design data of road. The combination of Grade and Slope control and Navigation is called a positioning system, which is provided by many manufacturers. For positioning, laser-based total stations are available as well as mmGPS.

Standard equipment

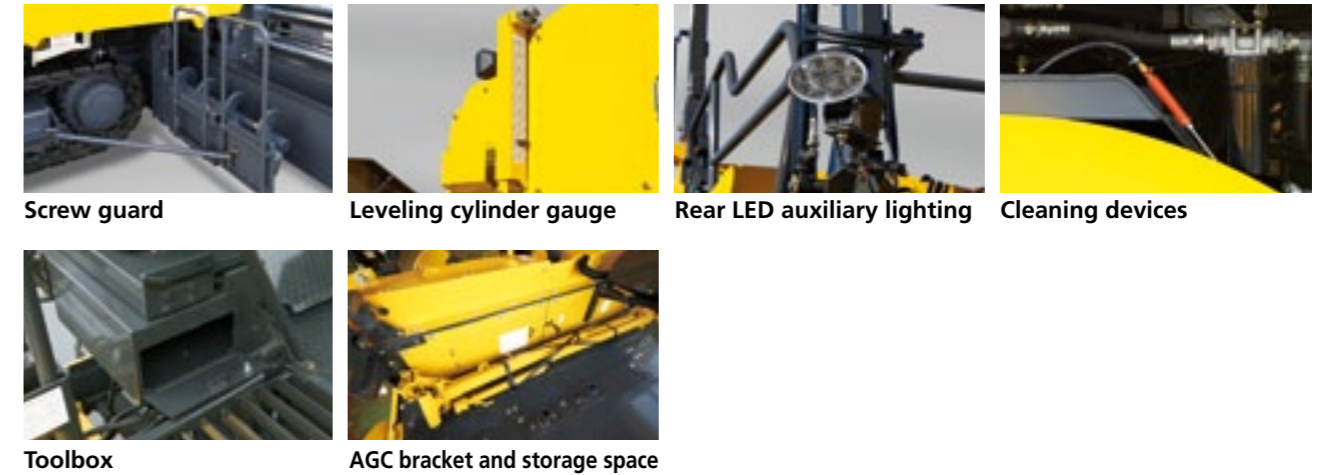

Special equipment (option)

AVS (Asphalt fume Ventilation System)

Sumitomo's AVS has two functions that make working operations safer and more comfortable.

1. After the air cools the radiator, it blows away fumes from the hopper.
2. The hydraulic fan draws fumes from the area between tractor and screed, and blows them away from the outlet installed outside of the engine exhaust pipe.

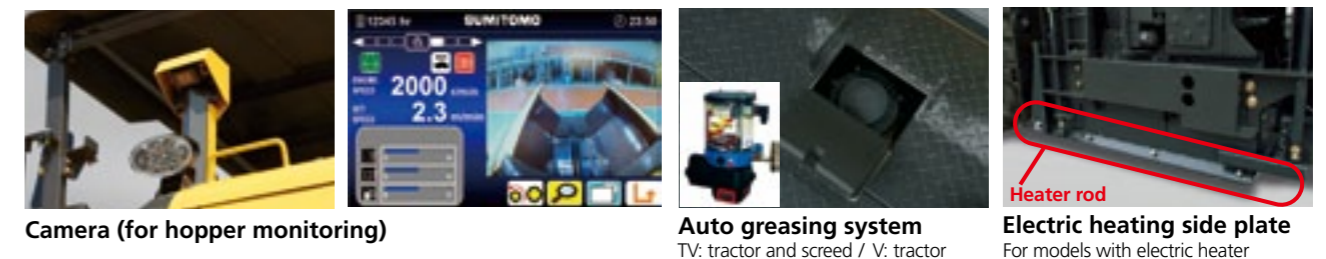
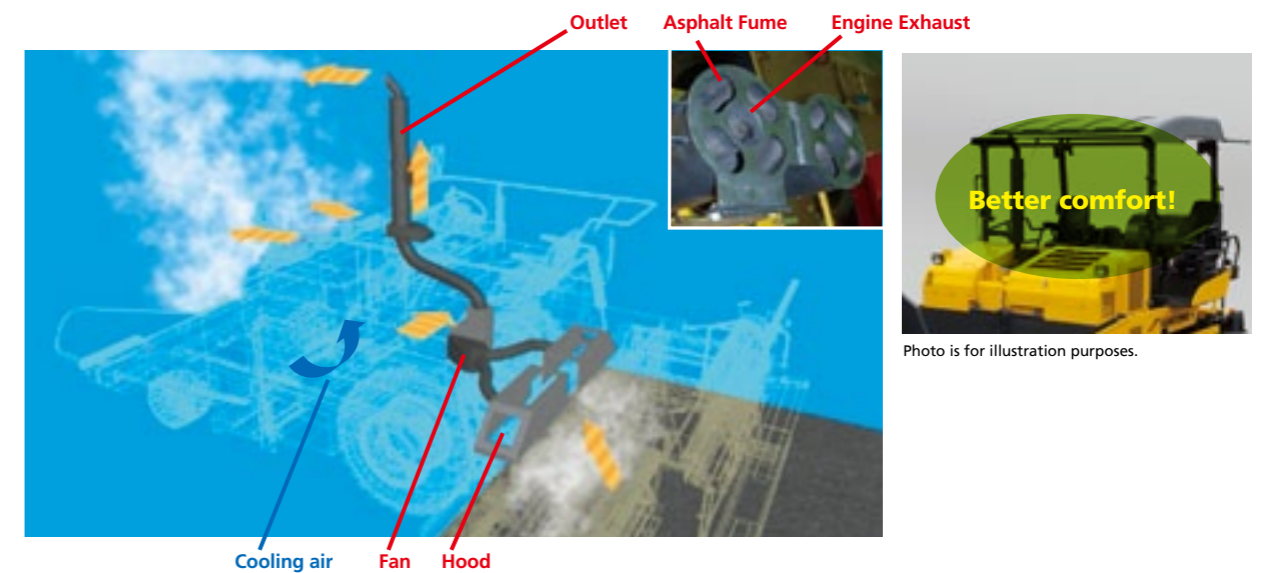

Principle Specifications

		HA60C-8B	HA60W-8B	
Paving performance	Paving width	2.3~6.0 m infinitely variable		
	Paving thickness	10~300 mm		
	Paving speed	1~20 m/min		
	Hopper capacity	13 ton		
	Center crown ratio / Side slope ratio	-1~3 (Hyd.) / 0~3 %		
Dimensions	Operating weight (LPG heating)	14730 kg	14990 kg	
	Operating weight (Electric heating)	15000 kg	15260 kg	
	Overall length	6620 mm	6930 mm	
	Overall (transportation) width	2490 mm	2490 mm	
	Overall height (with canopy)	2740 (3790) mm	2765 (3790) mm	
	Transportation height (with canopy)	2740 (2915) mm	2765 (2915) mm	
	Wheel base / Tumbler distance	2615 mm	2700 mm	
	Crawler width	284 mm	—	
	Tires	—	Front 22 x 14 x 16 (solid) Rear 15.5R25	
Conveyor system	Type of driving method	Hydraulic (individual left & right)		
	Width x No. of line	482 mm x 2		
	Rotating speed	0~15.9 m/min		
Auger system	Auger dimensions	330 dia. x 300 pitch mm		
	Rotating speed	0~82 min ⁻¹		
Screed system	Model	JPaver 2360		
	Heating system	LPG blower burner / Electric (option)		
	Compaction system	Type	Tampers and vibrator	
		Vibrator frequency	0~50 Hz (3000 cpm)	
		Tamper rotating speed	0~20 Hz (1200 cpm)	
	Height adjustment of extendable screed	Hydraulic		
Height adjustment of extendable mold board	Hydraulic			
Drive system	Type of driving method	Crawler (Track)	Wheel (Tire)	
	Drive method	HST	Front; Hyd. Motor / Rear; HST	
	Brake type	Automatic brake	Automatic brake	
	Traveling speed (Forward / Backward)	0~3 / 0~3 km/h	0~15 / 0~10 km/h	
Engine	Make & model	ISUZU 4JJ1X (EU Stage III B / EPA Interim Tier 4)		
	Displacement	2999 cc (4CYL.)		
	Rated output	92.2/2200 kW/min ⁻¹ (125.3 hp)		
	Fuel tank capacity	140 L		
	Electric system	24 V		

Equipment Items

		HA60C-8B	HA60W-8B
Push roller	Oscillating push roller	○	○
	Hydraulic operated hopper front	○	○
Hopper	Individual operated wings (L&R)	○	○
	Hydraulic height adjustment & reversible auger	○	○
Operator seat	Left & right seat	○	○
	Slide-out seat	○	○
	Deluxe seat (Suspension type)	○	○
Electric	Grade & slope sensor (Contact / Ultrasonic)	●	●
	Material flow controller (Auger rotation control)	●	●
	Front wheel traction control	—	○
Hydraulic	Brake steering	—	●
	Screed anti-climb lock	●	●
	Hydraulic center crown	○	○
	Hydraulic height adjustment of extendable screed	○	○
Screed	Hydraulic height adjustment of extendable mold board	○	○
	Auto. Temp. control for LPG heating	○	○
	Electric heating	●	●
Others	Electric heating side plate	●	●
	Hard top canopy (FRP)	○	○
	Canopy folding and Emergency control by hand pump	○	○
	Auto greasing system	●	●
	AVS (Asphalt fume Ventilation System)	●	●
Crawler blade	●	—	

Sales specifications, accessories and other items may differ depending on country or region. Ask for details during sales negotiations.

Dimensions (mm)

HA60C-8B [Crawler Type] (with optional equipment)

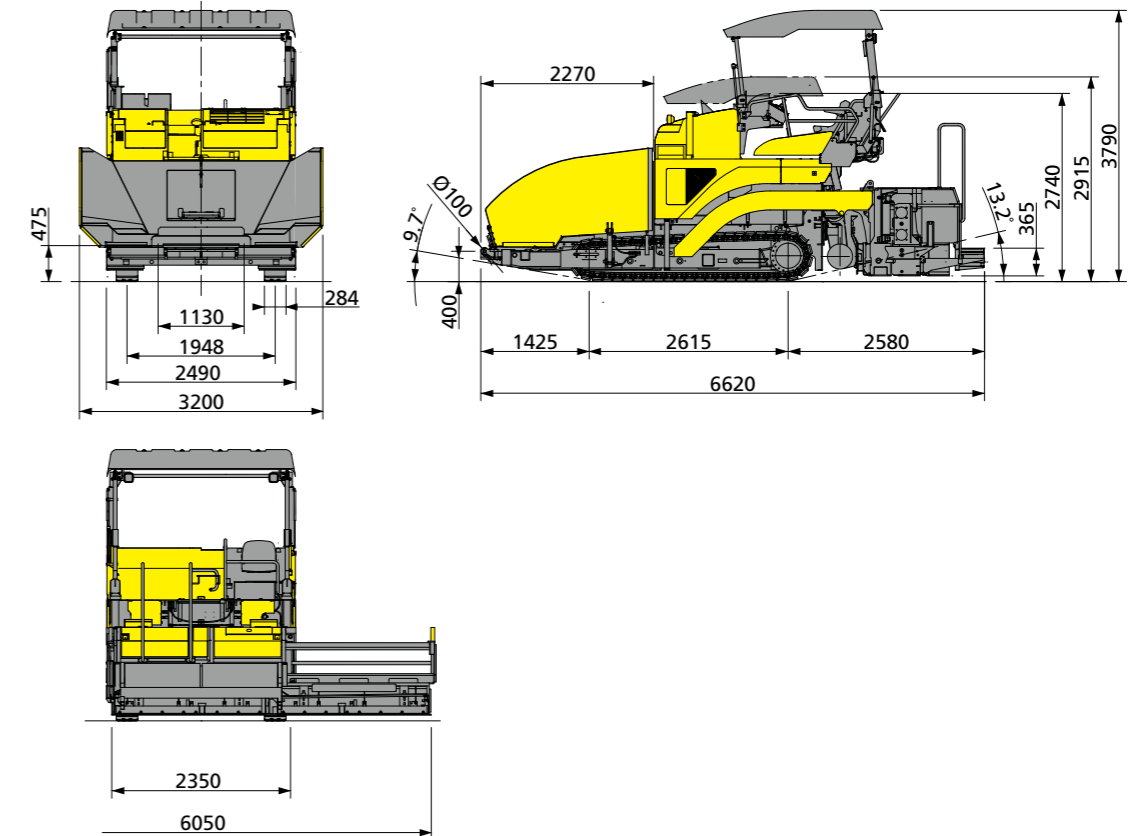

HA60W-8B [Wheel Type] (with optional equipment)

