

# SUMITOMO

# SUMITOMO PAVERS

Sumitomo Asphalt Paver  
**J-PAVER**  
**HA60C-11**  
EU Stage V



 **SUMITOMO CONSTRUCTION  
MACHINERY CO., LTD.**

731-1 Naganumahara-cho, Inage-ku, Chiba, 263-0001 Japan

For further information please contact :

Phone : +81-43-420-1829 Facsimile : +81-43-420-1907

<https://www.sumitomokenki.com/>

We are constantly improving our products and therefore reserve the right to change designs and specifications without notice.  
Illustrations may include optional equipment and accessories and may not include all standard equipment.



# Paving the way. With our way.

## Outstanding Universality & Convenience.

The new generation of HA60C-11 is developed from Sumitomo's more than 60 years experience, and matches the latest EU Stage V emission standard.

SUMITOMO Pavers are designed under the concept of the following 3 points and manufactured with high quality.

- **Human Friendly**
  - **Eco Friendly**
  - **Repair Friendly**
- High Performance & Quality  
Universality & Convenience  
Powerful & ECO

# HA60C-11

EU Stage V



### WORLD FIRST

#### Infinitely variable triple screed

The J.Paver 2360 uses an enhanced frame structure to improve rigidity significantly, for more consistent and reliable paving operations.

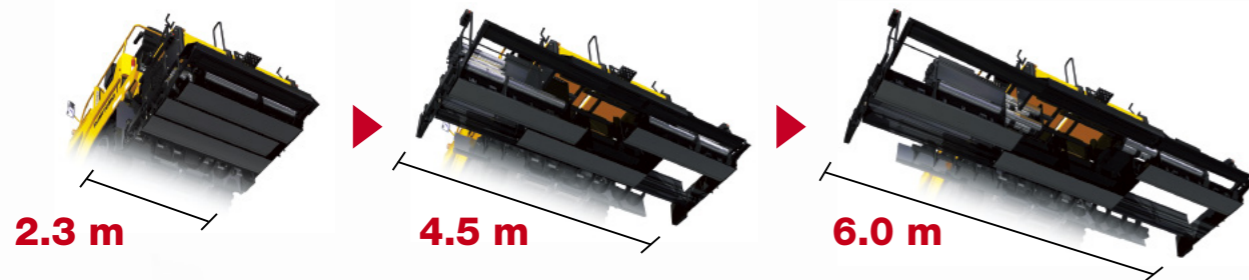

#### STV compaction system

Sumitomo's original **Strike-off** + **Tamper** + **Vibrator** combination. Strike-off leads material to the tamper smoothly, with this structure tamper and vibrator can perform enough compaction.

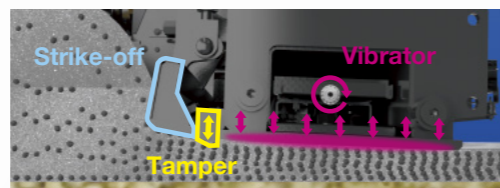

**2.3 m to 6 m**  
Increased working range with a single switch

#### Double role

The J.Paver 2360 covers two conventional screed ranges.

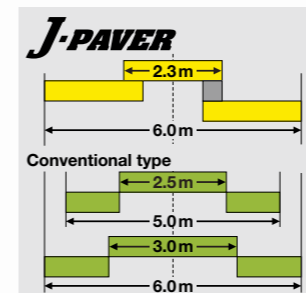

Within **2.5 m** transportation width



#### Easy transportation

The HA60C can be completely loaded onto a 2.5 m-wide trailer and paving can be started without having to assemble any parts.



# Powerful & ECO

20% more power with the same fuel consumption  
(compared to the HA60-8B)

## Powerful and ECO

### High-power torque and low fuel consumption engine

The power system, a combination of newly developed intelligent YANMAR engine and SUMITOMO's cutting-edge technology, delivers high work efficiency and low fuel consumption. The YANMAR-4TN107 meets the EU Stage V emission standard.

©YANMAR-4TN107  
(Single turbo + Intercooler)

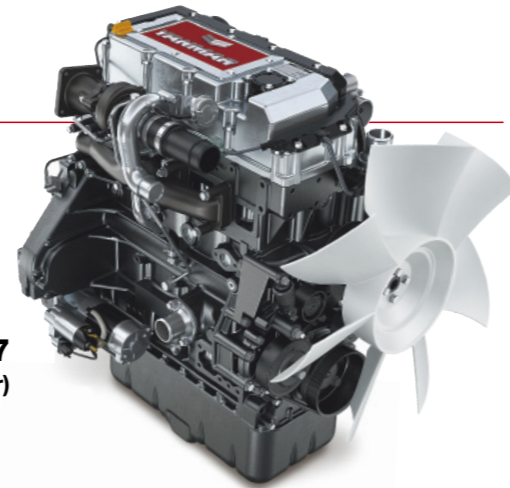

### SCR System

The Selective Catalytic Reduction System is one of the most cost-effective and fuel-efficient technologies for injecting AdBlue® (urea water) into the exhaust, where NOx undergoes a chemical reaction and converts exhausts gases into harmless nitrogen and water. Post-processing NOx allows results in more efficient engine combustion, thereby improving fuel efficiency and power generation.

AdBlue® is registered trademark of the German Association of the Automotive Industry.

### How the SCR system works

The SCR system comprises the oxidation catalyst, SCR catalyst, urea water injection unit and other devices. The first stage involves purifying PM in the exhaust by the oxidation catalyst. Urea water is then injected into the exhaust gas, and the action of ammonia in the urea water and the SCR catalyst reduces NOx to harmless nitrogen and water, resulting in clean exhaust gas.

### SCR (Selective Catalytic Reduction) System

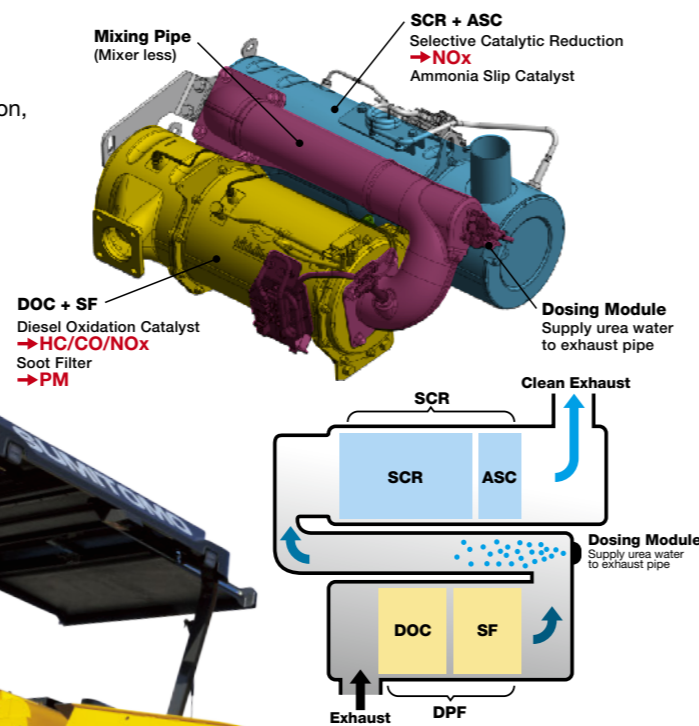

## Outstanding Convenience

### Electric heating system

Sumitomo's latest control system delivers ecologically optimized heating and easy maintenance.

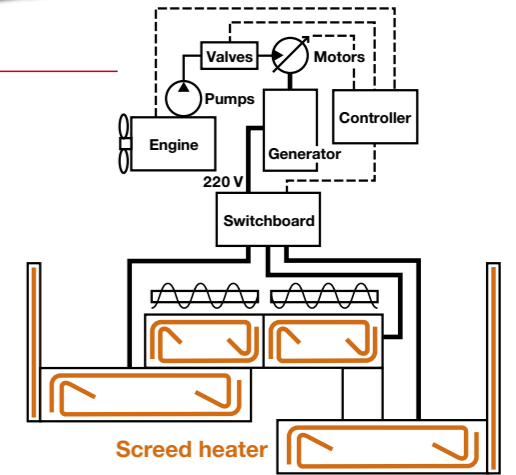
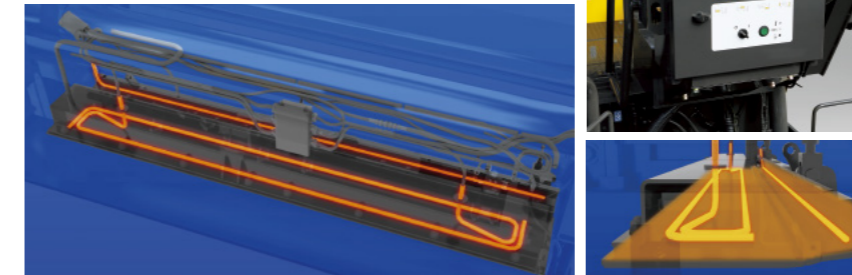

### Height of extendable screeds

When a difference in surface height occurs between front and rear screeds, it can be adjusted by just a flick of a switch.

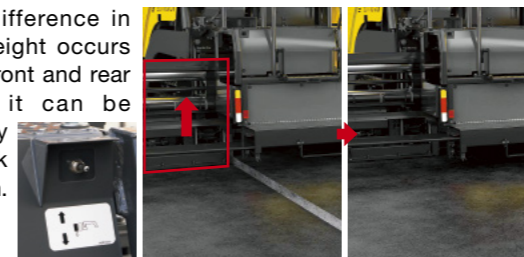

### Crown Adjustment

The slope from center to side can be adjusted by a switch on the hydraulic crown device.

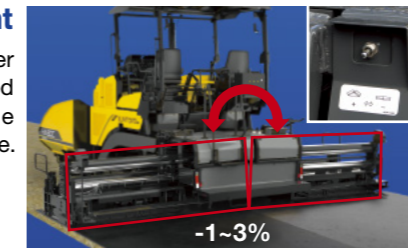

### Extendable mold board (Powered type)

The extendable mold board extends together with the screed, and cuts off the material to avoid over capacity in front of the rear screed. It also carries material smoothly to the end of the screed.

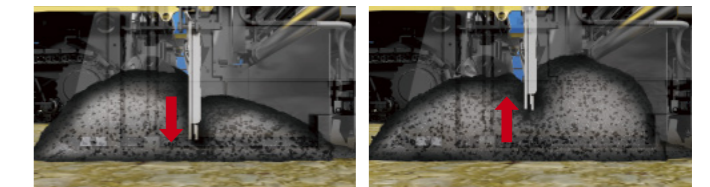
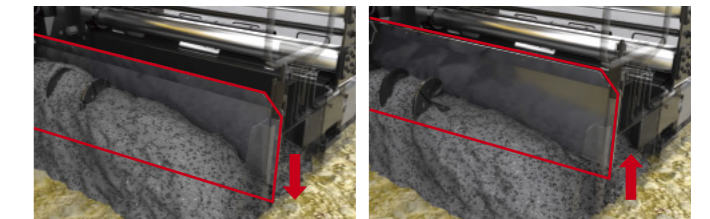

Hydraulic height adjustment

### Automatic screed lock

When the automatic lock device is activated, the screed lift cylinder prevents (holds) the screed from sinking into the surface when the machine stops.

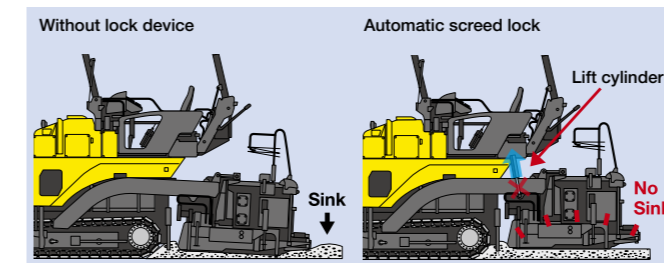

### Anti-climb lock

When the anti-climb lock device is activated, the screed lift cylinder prevents (holds) the screed from floating up to the surface when the machine stops.

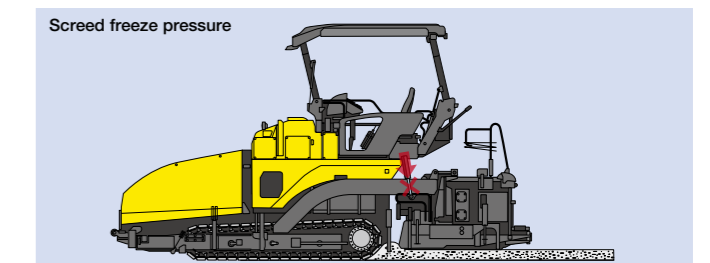

Free: → Pressure: → Lock (hold): ×

# High Performance & Quality



## Material Supply System

### New hopper shape

The hopper's leading edge is low to suit dump trucks with low bumpers. The hopper also has ample supply capacity.



The hopper front apron is operated by two hydraulic cylinders, which keeps material inside the hopper and prevents it from spilling onto the ground.



### Individual operating hopper wings

This function is useful to avoid obstacles on the road. It also allows for operation depending on the volume of material.



### Reversible auger conveyor

A perfect balance of material in front of the screed can be achieved by this function.



### Oscillating push roller

When paving a curved road, the push roller is contacting the tire of the dump truck constantly.



### Auger height adjust switches

The height of the auger can be adjusted hydraulically according to the paving thickness. Adjust switches are located on the operator console and behind the screed arms.

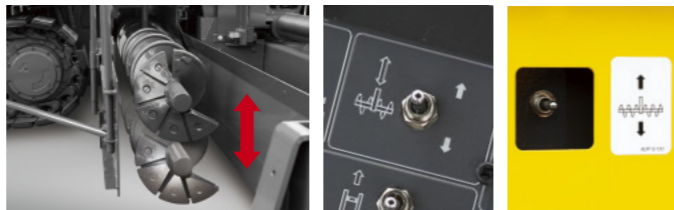

## Comfortable Operation

### Movable operator console

The operator console can be moved from left to right to provide the operator with greater flexibility, with the force required for movement half that of the HA60-8B.

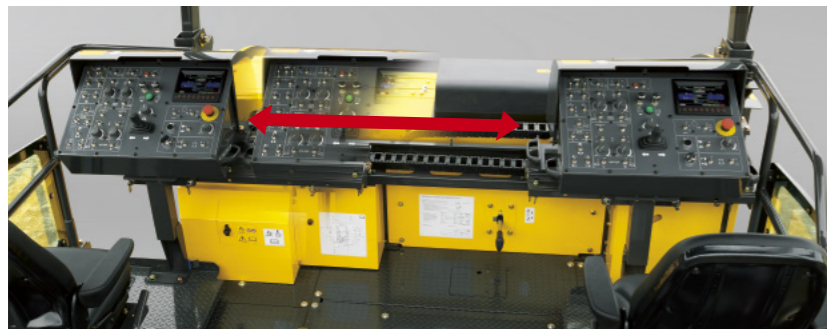

### Slide out seat

The slide out seat is useful for checking the road and working conditions. The operator console can also slide to suit the seat, with the force required for movement half that of the HA60-8B. The deluxe suspension seat also adds a higher level of comfort.



### Smooth steering

The machine is controlled automatically, with left and right side traveling speeds being set to curve in a continuous smooth arc without losing traction force.

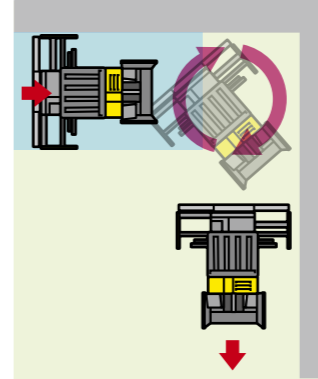

### Spin-turn

This function makes it possible to turn on the spot, which is very useful on cramped job-sites such as dead ends.



### Self neutral type direction stick

The direction stick has a self neutral design, to prevent operating accidents.

### Foldaway retaining plate

Extremely useful for feeding materials outward smoothly. The plate is stowed completely within the machine width.

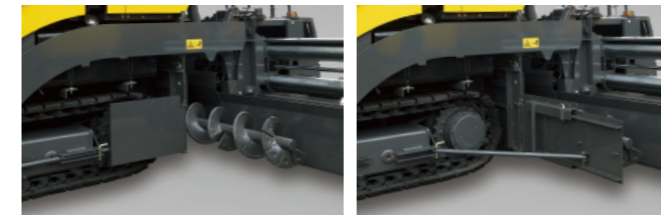

### Auto. Tamper speed setting

Tamper is automatically adjusted to a suitable speed according to the paving speed.

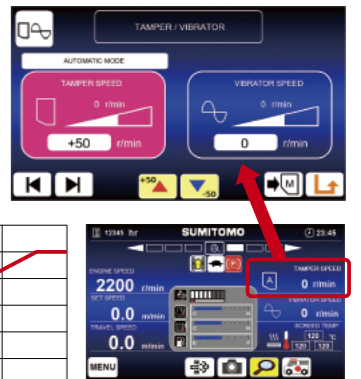
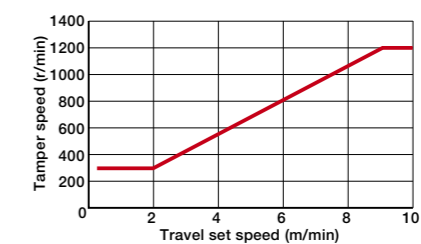

### Improvements to smoothness attained by superior surface contact

The oscillating bogie absorbs impacts from uneven road surfaces, such as those created by manholes.

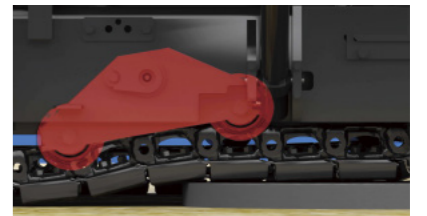

### Crawler blade (option)

The crawler blade scrapes off the spilled material in front of the shoe.



### Hard top canopy

The new FRP (Fiber Reinforced Plastic) canopy is operated hydraulically during opening and closing.



### Slide out type sunshade

With the new designed FRP Canopy, the new slide out type sunshade is much bigger, easy to operate and gives the operator stand more comfort.



### Side windshield

The newly designed side windshield prevents strong winds and helps maintain a clear field of view.



# Easy & Safe



## New Operator Console Layout

### Operator console

Switch positions are arranged by functions. A full-color display is equipped on the operator console, which is designed for ease of use. In the event that the screed console is faulty, this main console can also be used for operations.



- A Emergency travel control switch**  
Enables manual operation if travel operation is disabled because of controller breakdown.
- B Screed control**  
Screed up and down, screed hook, screed extend and retract, left and right leveling adjustment.
- C Hopper**  
Hopper can be operated individually (Left or Right), also together (Left and Right).
- D Auto leveling mode switch**  
To use together with leveling sensors to achieve the settled paving thickness.
- E Auger height adjust switch**  
To adjust auger height position Up & Down.
- F Conveyor control switches**  
To adjust supply speed, direction.
- G Auger control switches**  
To adjust spread speed, direction, or auto operating with material flow sensor.
- H Steering control**  
Steering by stick + dial, also the spin turn switch is equipped.
- I Engine control**  
When ECO mode is selected, the engine speed will be reduced to 2,000 min<sup>-1</sup>, further reducing fuel consumption.
- J Travel control**  
High or Low travel speed. Forward or backward, travel ON or OFF.

### Full color display

The operator console has a 7-inch wide full-color display that is easy to read even in bright places. Most working conditions can be set through the buttons below, machine status, maintenance and other important information can also be collected.

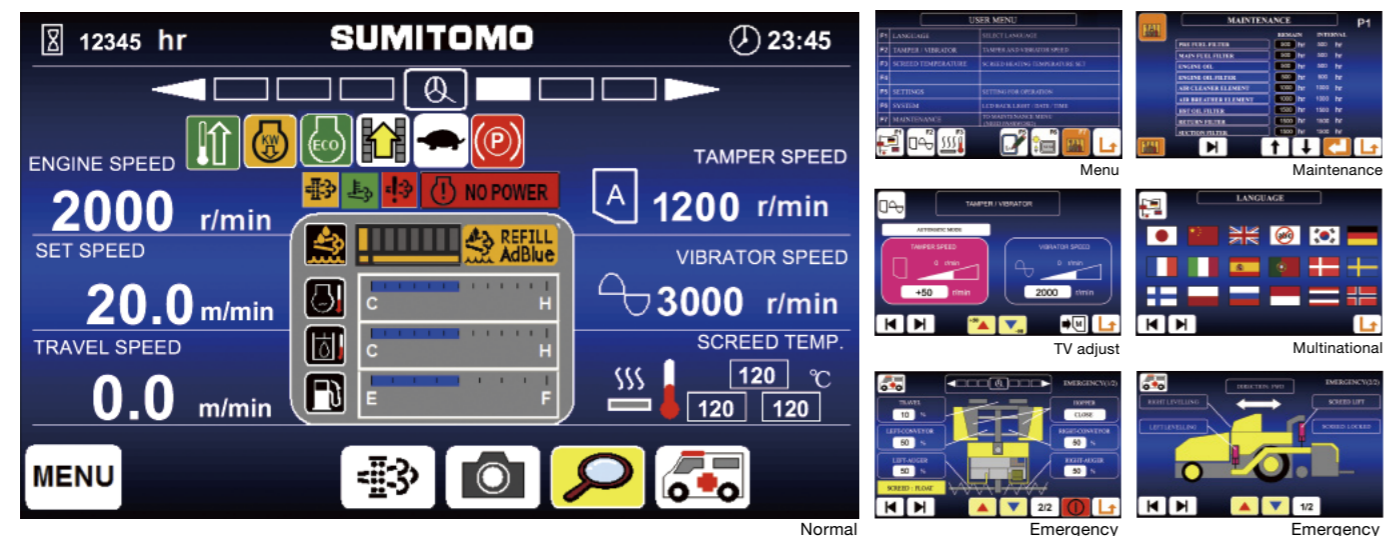

### New screed console with color display

Key functions are arranged on the left and right screed console, and the auger and conveyor can also be operated individually. The color sub displays indicate the performance in figures. Tamper & vibrator, heating temperature, etc. settings are also available with push the buttons below. Emergency stop buttons are also equipped for safety.



### Eco Mode switch

The Eco Mode switch drops the engine speed from 2,200 min<sup>-1</sup> to 2,000 min<sup>-1</sup> under light loads, which is useful for reducing fuel consumption.



Eco Mode switch

### Front camera (option)

Monitoring vision of the hopper and surrounding areas gives the operator a clearer view for greater efficiency and team safety.



### Emergency stop button

This is an emergency stop button to be pressed in case of emergency.



An icon is displayed on the monitor when the emergency stop button is activated.

### FVM (Field View Monitor) (option)

Sumitomo has developed the world's first revolutionary safety device, Field View Monitor (FVM). The primary feature of the device is its ability to provide a maximum range view of 270 degrees - mostly in the front and rear of the equipment - on a full color monitor. The technology that dramatically expands the view of the operator will probably set the standard for construction sites that demand a higher level of safety.



Wide field of view  
**270° to the front!**

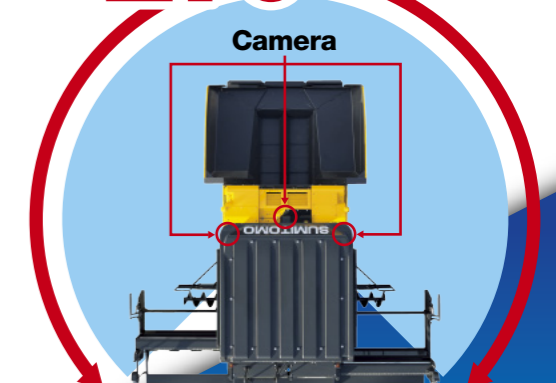

# Maintenance and featured options

## Easy maintenance

Daily inspections are extremely straightforward. Oil and grease checks, filter changes as well as other maintenance jobs can be easily carried out just by opening the covers.

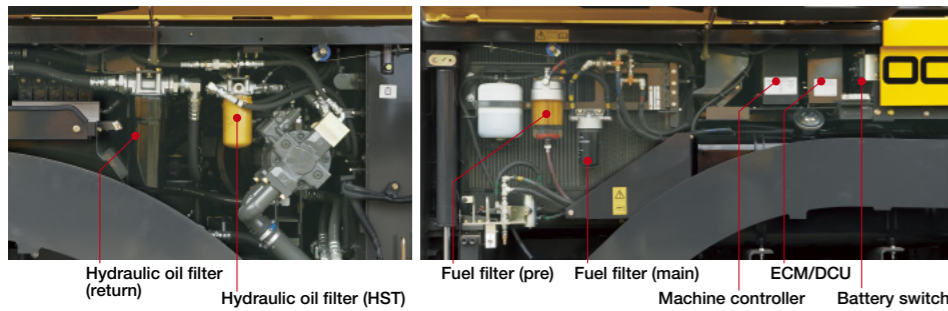

Hydraulic oil filter (return) Hydraulic oil filter (HST) Fuel filter (pre) Fuel filter (main) ECM/DCU Machine controller Battery switch



Engine oil filter

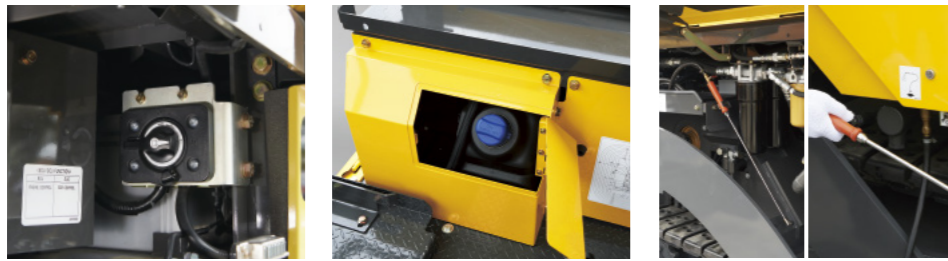

Battery switch AdBlue® tank Cleaning devices (both sides)

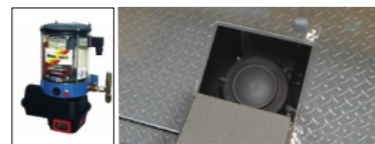

Auto greasing system  
TV: tractor and screed / V: tractor

### Grease feeding points

Tractor		Screed		
Conveyor idler	Conveyor drive	Auger	Tamper	Leveling bearing
4	2	4	16	2

## Emergency evacuation system (option)

If the engine or pump malfunction during paving, this function allows the machine to be moved to a safe location away from the road.



\*The hydraulic hand pump can operate the cylinders of the hopper, screed extend and screed lift.

## AVS (Asphalt fume Ventilation System) (option)

The hydraulic fan draws fumes from the area between tractor and screed, and blows them away upward of canopy.

## Side plate heater (option)

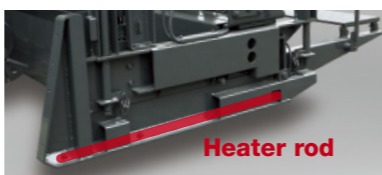

Heater rod

## Automation for convenience

Grade sensors, slope sensors, 3D control systems and other devices for automation can be used with Sumitomo's pavers to make operations more convenient.

	Device	Type
①	Grade sensor	Contact / Ultrasonic
②	Slope sensor	Conventional / Digital
③	Big-Ski	3 / 4 Sonic
④	Material flow sensor	Auger rotation speed
⑤	3D-Machine control	GPS / Total station



## Principle specifications

		HA60C-11
Dimensions	Paving width	2.3-6.0 m infinitely variable
	Paving thickness	10-300 mm
	Paving speed	1-20 m/min
	Hopper capacity	12 ton
	Center crown ratio / Side slope ratio	-1~3% (Hyd.) / 0~3%
	Overall length	6,590 mm
	Overall (Transportation) width	2,490 mm
Conveyor system	Overall height / Transportation height	3,765 mm / 2,920 mm
	Operating weight	15,900 kg
Auger system	Width x No. of line	400 mm x 2
	Rotating speed	0-15.9 m/min
Screed system	Auger dimensions	330 dia. x 300 pitch mm
	Rotating speed	0-82 min <sup>-1</sup>
Drive system	Model	J-Paver 2360
	Heating system	Electric
	Compaction system	Tamper & Vibrator
	Type of driving method	Crawler (Track)
Engine	Drive method	HST
	Brake type	Automatic brake
	Traveling speed	0-3 km/h
Engine	Make & Model	YANMAR-4TN107 (EU Stage V)
	Displacement	4,567 cc (4 CYL.)
	Rated output	110/2,200 kW/min <sup>-1</sup> (ECO MODE 108/2,000 kW/min <sup>-1</sup> )
	Fuel tank capacity	180 L

## Dimensions

HA60C-11 [Crawler Type] (with optional equipment)

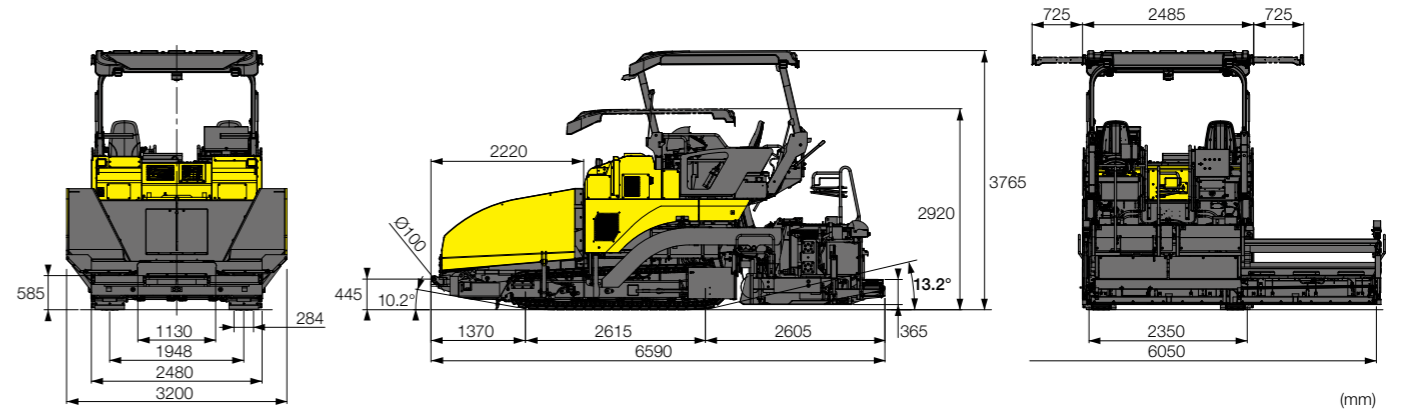

## Standard equipment

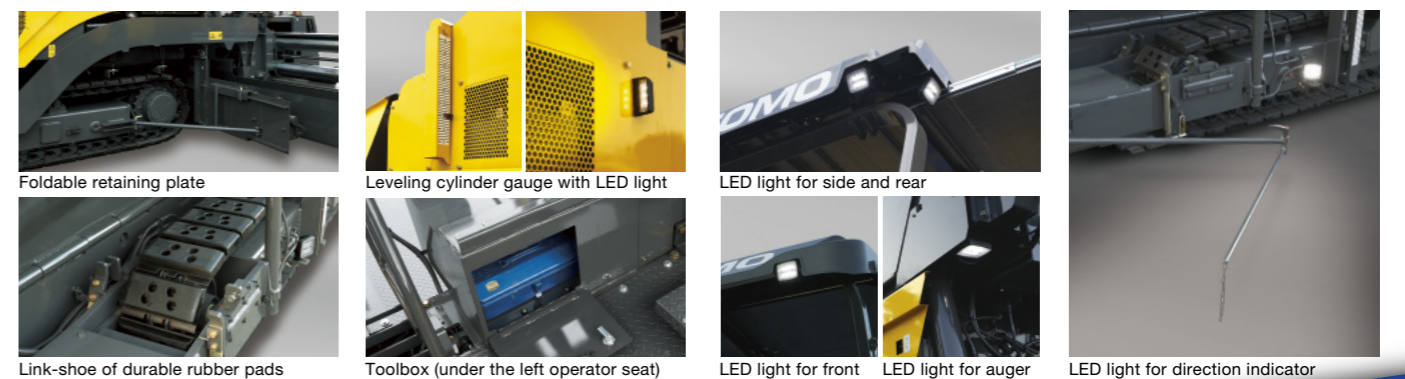

## Equipment items

◎ Standard ● Option

		HA60C-11
Push roller	Oscillating push roller	◎
Hopper	Hydraulic operated hopper front	◎
	Individual operated wings (L&R)	◎
Auger	Hydraulic height adjustment (150 mm)	◎
	Reversible auger	◎
Operator seat	Left & right seat	◎
	Slide-out seat	◎
	Seat heater	●
Sensor	Grade & Slope sensor (Contact/Ultrasonic)	●
	Material flow controller (Auger rotation control)	●
	Screed anti climb lock	◎
Screed	Hydraulic center crown	◎
	Hydraulic height adjustment of extendable screed	◎
	Hydraulic height adjustment of extendable mold board	◎
	Auto. Tamper speed setting	◎
	Electric heating (3CH control)	◎
	Side plate heating (Electric)	●
Others	Hard top canopy (FRP) (Hydraulic operation)	◎
	Emergency control system by hand pump	●
	Auto greasing system (Inc. screed)	●
	Crawler blade	●
	FVM (Field View Monitor) (3 cameras)	●
	Hopper camera (1 camera)	●
	Side window shield	◎
Front window shield	●	
	AVS (Asphalt fume Ventilation System)	●