

MACHINES

# APF VIBRATORY PLATES

APF SERIES FORWARD MOVING  
VIBRATORY PLATES



**AMMANN**

# PRODUCT OVERVIEW

## AMMANN APF FORWARD MOVING VIBRATORY PLATES

Seven forward-moving vibratory plate models provide a solution for virtually all jobsite challenges.



### APF 10/33 – PETROL

Weight: 54 kg (119 lb)  
Working width: 330 mm (13 in)  
Centrifugal force: 10.5 kN (2360 lbf)  
Vibration frequency: 100 Hz (6000 VPM)



### APF 12/40 – PETROL

Weight: 69 kg (152 lb)  
Working width: 400 mm (15.7 in)  
Centrifugal force: 12 kN (2698 lbf)  
Vibration frequency: 98 Hz (5880 VPM)



### APF 12/50 – PETROL

Weight: 72 kg (159 lb)  
Working width: 500 mm (19.7 in)  
Centrifugal force: 12 kN (2698 lbf)  
Vibration frequency: 98 Hz (5880 VPM)



### APF 15/40 – PETROL

Weight: 80 / 84 kg (176 / 185 lb)  
Working width: 400 mm (15.7 in)  
Centrifugal force: 15 kN (3372 lbf)  
Vibration frequency: 100 Hz (6000 VPM)



### APF 15/50 – PETROL

Weight: 84 / 88 kg (185 / 194 lb)  
Working width: 500 mm (19.7 in)  
Centrifugal force: 15 kN (3372 lbf)  
Vibration frequency: 100 Hz (6000 VPM)



### APF 20/50 – PETROL

Weight: 88 kg (194 lb)  
Working width: 500 mm (19.7 in)  
Centrifugal force: 18 kN (4047 lbf)  
Vibration frequency: 90 Hz (5400 VPM)



### APF 20/50 – DIESEL

Weight: 106 kg (234 lb)  
Working width: 500 mm (19.7 in)  
Centrifugal force: 18 kN (4047 lbf)  
Vibration frequency: 90 Hz (5400 VPM)





## APPLICATIONS

- Compaction in confined areas
- Asphalt and paving
- Light to medium patchwork
- Pipeline and trench construction
- Landscaping and gardening
- Earthwork

## PRODUCTIVITY

### Large exciter unit

Boosts power, speed, climbing ability and machine life.

### Toolless mountable water tanks

Enable simple refilling.

### Toolless mountable rubber mats

Provide quick changes when it's time for a new application.

## ERGONOMICS

### Low HAV levels (below 2.5 m/sec<sup>2</sup>)

Protect the operator from unwanted vibration.

### Quick and easy mounting of options (water tank, Vulcolan mat, transport wheels)

Make the most of operator and machine time.

### Machine frame that enables secure grip

Helps the operator control the machine, even in difficult spaces and confined areas.

## SERVICEABILITY

### Maintenance-free exciter system

Reduces wear and maintenance costs.

### Full engine frame

Protects against damage on the jobsite or during transport.

### Toolless daily maintenance

Fast and convenient for optimal uptime.



# TECHNOLOGICAL FEATURES ADD EFFICIENCY

All Ammann plates are easy to operate, making them ideal for rental fleets. They also are versatile, with an ability to easily adjust to varied applications. Many are available with diesel or petrol engines.

## PROTECTION FRAME

New frame protects engine also keeping easy access for maintenance and easy for transport

## ENGINES

Plates are available in two main engine versions petrol or diesel



## VIBRATION SYSTEM

Combination of high performance and maintenance free vibratory system delivers exceptional results

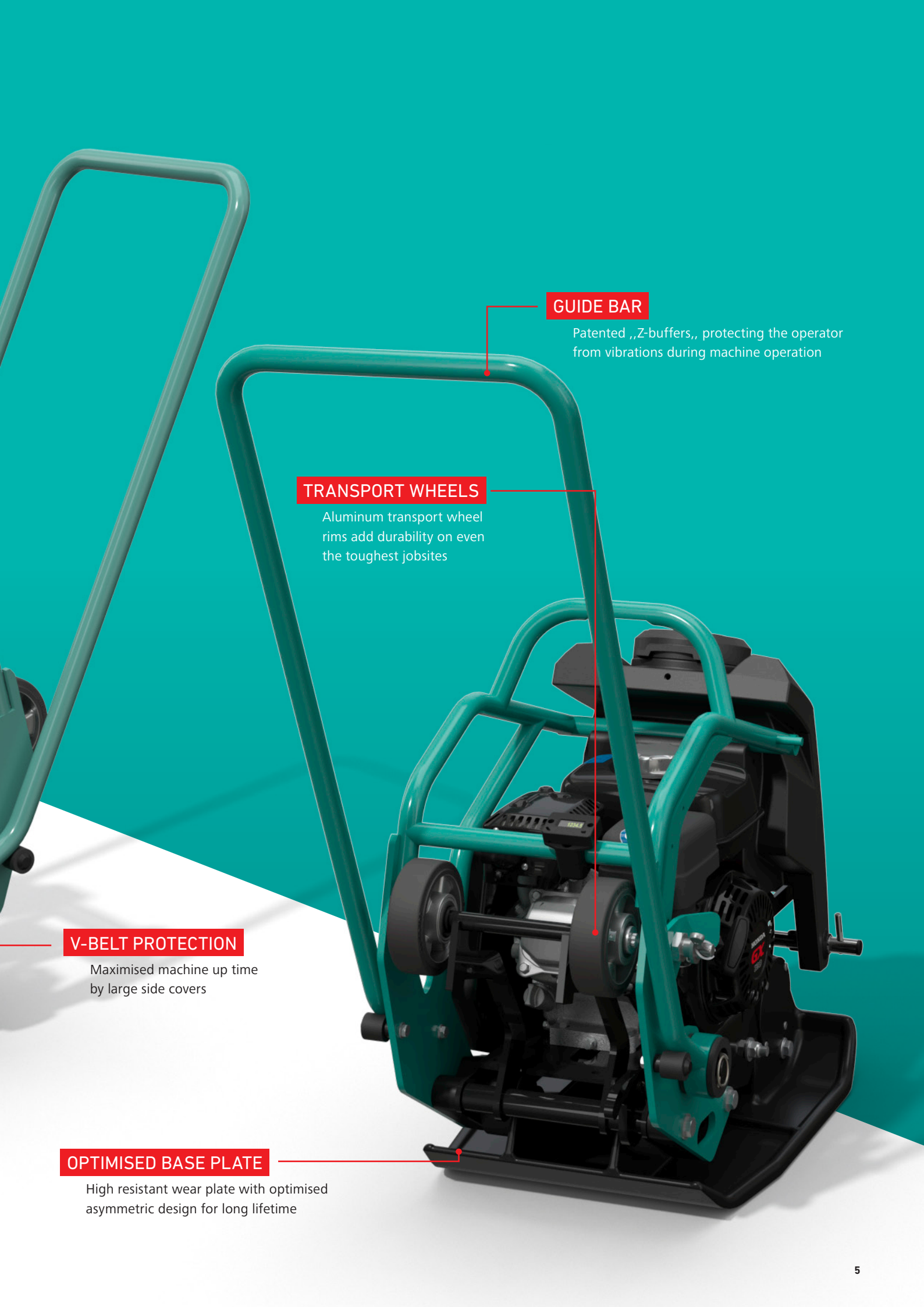

**GUIDE BAR**

Patented „Z-buffers,, protecting the operator from vibrations during machine operation

**TRANSPORT WHEELS**

Aluminum transport wheel rims add durability on even the toughest jobsites

**V-BELT PROTECTION**

Maximised machine up time by large side covers

**OPTIMISED BASE PLATE**

High resistant wear plate with optimised asymmetric design for long lifetime

# PRODUCTIVE ALL AROUND

THE EXTRA BENEFIT FOR YOUR SUCCESS

Technology and innovative design are the driving forces behind the durability, productivity and operator comfort built into every Ammann forward-moving vibratory plate.



## RELIABLE POWER

The APF line is powered by reliable and efficient Honda or Vanguard petrol engines. The APF 20/50 is available with a petrol or a Hatz diesel engine, which performs well in high altitudes and enables the use of a single fuel type on many jobsites.

The sturdy protection frame on all engines prevents damage during operation or transport, and ultimately extends plate life.

## PRODUCTIVITY ON ALL GROUND

Ammann APF plates are great all-around machines, providing the solutions to work on every kind of jobsite where compaction is required. Their small size and productivity make them a valuable addition to every machine fleet.

## TOOLLESS MOUNTABLE WATER TANK

When working with bituminous materials, the APF plate can be equipped with a water tank and sprinkling system. The add-on tank can be quickly mounted on the machine – no tools required.

Refilling is easy, too. Simply remove the tank and carry it to the nearest water source.

## TOOLLESS MOUNTABLE RUBBER MAT

Ammann APF plates excel when working with paving stones. Each machine can be equipped with a rubber mat that prevents the stones from being scratched or cracked. No tools are required to mount or remove the mat, enabling quick switches between applications.

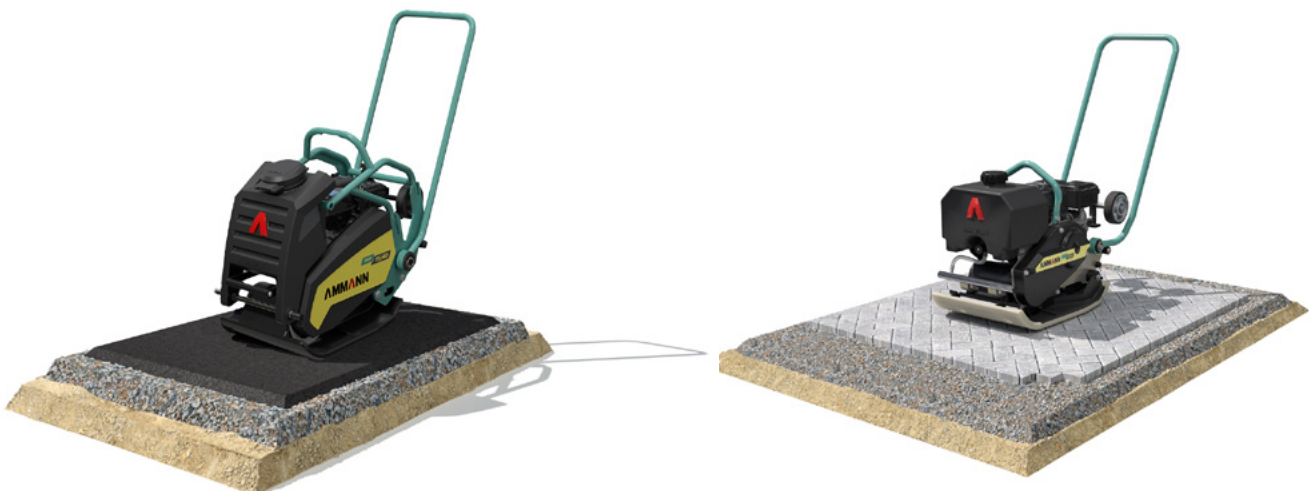



# THE ERGONOMICS LEADER

A JOY TO WORK WITH

Ammann APF plates are at the top of the class when it comes to operator safety and ergonomics. The plates offer the reliability and precise control necessary to adjust to changing jobsite challenges. Intuitive operation helps plate operators of all experience levels succeed.



## REDUCES UNWANTED VIBRATION

Ammann plates lead the industry in lowest hand-arm vibration (HAV) levels. In fact, the levels are so minimal that the machines will remain in compliance with the strictest regulations for many years to come.

The reduced vibration values (below 2.5 m/sec<sup>2</sup>) result from the Z-buffer in the handle bar. This patented system enables long work shifts without health risk to the operator – or a need for documentation.

The handle can be folded so it is flush with the machine and protected during transport.



## HIGHLY MANOEUVRABLE

The powerful forward movement of the plates boosts productivity and enables consistent results, even on steep grades. The base plate is designed to add forward-moving efficiency. The handle and grip on the machine frame help the operator manoeuvre the compactor in tight spaces.



## EASY TRANSPORT

A central, easy-to-grip transport hook makes it simple to lift the plate while loading it into a vehicle or removing it from trenches. The plate is small enough to fit into a vehicle of any size.

# A WORTHY INVESTMENT

HIGH QUALITY COMPONENTS MAKE YOUR AMMANN APF PLATE LAST

Plate compactors face many challenges on jobsites – including materials that are difficult to compact, long working hours and continuously supplying the powerful vibration required to provide productivity. Ammann plates are built to meet these daily challenges. Their durability ensures success on the current jobsite – and those that follow, too.

## V BELT PROTECTION

Machine uptime is maximised by large side covers, which fully protect the V belts that provide the compaction power.

## TRANSPORT WHEELS

Optional aluminum transport wheel rims add durability on even the toughest jobsites.



## VIBRATORY SYSTEM

The powerful vibratory system provides the productivity needed. It also features extended service intervals that reduce the cost of ownership and make Ammann plates more environmentally friendly, too.

## BASE PLATE

All Ammann forward-moving machines are equipped with base plates made from high-resistant steel. In addition, APF base plates are manufactured with no bended metal and no welded parts, so there are no weak spots. The design further boosts machine life. The base plates feature thicker protection in the rear, where the most wear occurs. The smart design and use of wear-resistant steel are so effective that base plate service is not required during the life of a machine that operates under typical working conditions.



**“Proven technology and years of experience are reflected in every model in the APF range.”**





“The versatility of the Ammann APF Vibratory Plates makes them a perfect fit for every jobsite.”





# APF 10/33

# APF 12/40

# APF 12/50

## FORWARD MOVING VIBRATORY PLATE

### SUPERIOR MOBILITY AND PERFORMANCE

The APF 10/33, APF 12/40 and APF 12/50 are the lightest and smallest vibratory plates in the Ammann portfolio. Their compact size makes them ideally suited to small jobsites and confined areas.

These forward-moving vibratory plate compactors are often used by landscape contractors to reach hard-to-access spots. The APF 10/33, APF 12/40 and APF 12/50 are also popular with home-owners because of their manageable size. When the work is done, the compactors are small enough to fit in the boot of a car. The APF 12/50 features a working width of 500 mm (19.7 in).

### SMALL ALL-AROUND MACHINES FOR EVERY TASK

These units have been designed to work in confined spaces on soil and on asphalt. The range of applications includes light to medium sized patchwork and tight jobsites, including obstacles such as curbs or retaining walls. A water sprinkling system with a water tank is available as an option.

### OPTIONS

Both models are available with a water sprinkling system to work on bituminous materials. The water tank is mounted onto the machine frame.

#### APF 10/33

- 5 l (1.3 U.S. gal) water tank and sprinkling system

#### APF 12/40 and APF 12/50

- 10 l (2.6 U.S. gal) water tank and sprinkling system
- Rubber mat
- Transport wheels



### HIGHLIGHTS

- Well-protected, robust centrifugal clutch with wear-resistant V belt
- Powerful petrol engine
- Wear-resistant, self-cleaning base plate
- Optional water sprinkling system for work on bituminous surfaces
- Optional transport wheels for simple relocation (APF 12/40 and APF 12/50)



# APF 15/40

## FORWARD MOVING VIBRATORY PLATE

### BROAD APPLICATION RANGE

The APF 15/40 utilises key options to make the forward-moving plate extremely versatile. An optional Vulcolan mat, which can be installed without a single tool, provides quick adjustment when working with paving stones. A sprinkling system enables work on asphalt. The plate features a working width of 400 mm (15.75 in).

The plate's technologically advanced exciter unit is maintenance free, with cylindrical bearings that reduce wear. The exciter system also provides significant forward-moving power to enhance productivity in challenging materials and on steep grades.

Ammann plates lead the industry in lowest hand-arm vibration (HAV) levels. The levels are so minimal that the machines will remain in compliance with the strictest regulations for many years to come.



### HIGHLIGHTS

- Low-vibration handle for operator safety and comfort
- Maintenance-free exciter system
- Self-cleaning, wear-resistant base plate
- Engine frame for protection on the jobsite and during transport
- Transport wheels, which can be dropped with a foot release, that enable mobility on the jobsite

# APF 15/50

## FORWARD MOVING VIBRATORY PLATE

### COMFORT AND OUTPUT

The APF 15/50 combines the powerful Ammann exciter system with industry-leading low hand-arm vibration (HAV) levels. The result is a powerful compactor that's comfortable and safe for operators, too. The plate features a working width of 500 mm (19.7 in).

The plate's technologically advanced exciter unit is maintenance free. The exciter system also provides significant forward-moving power to enhance productivity in challenging materials and on steep grades.

The APF 15/50 is able to utilise key options to make this forward-moving plate extremely versatile. An optional Vulcolan mat, which can be installed without a single tool, provides quick adjustment when working with paving stones. A sprinkling system enables work on asphalt.



### HIGHLIGHTS

- Low-vibration handle for operator safety and comfort
- Maintenance-free exciter system
- Self-cleaning, wear-resistant base plate
- Engine frame for protection on the jobsite and during transport
- Transport wheels, which can be dropped with a foot release, that enable mobility on the jobsite



# APF 20/50

## FORWARD MOVING VIBRATORY PLATE

### PACKING POWER

The APF 20/50 provides the most power in the APF lineup. It features a working width of 500 mm (19.7 in) and centrifugal force of 18 kN (4047 lbf). The plate's technologically advanced exciter unit is maintenance free. The unit also provides significant forward-moving power to enhance productivity in challenging materials and on steep grades.

Ammann plates lead the industry in lowest hand-arm vibration (HAV) levels. The levels are so minimal that the machines will remain in compliance with the strictest regulations for many years to come.

Key options make the APF 20/50 extremely versatile. An optional Vulcolan mat, which can be installed without a single tool, provides quick adjustment when working with paving stones. A sprinkling system enables work on asphalt. The APF 20/50 Vanguard has an engine output of 3.7 kW (5 hp), the most power in the APF lineup.



### HIGHLIGHTS

- Low-vibration handle for operator safety and comfort
- Maintenance-free exciter system
- Base plate that is self cleaning and wear resistant
- Engine frame for protection on the jobsite and during transport
- Transport wheels, which can be dropped with a foot release and enable mobility on the jobsite

The APF 20/50 Hatz combines all the benefits of other Ammann plates – but with a diesel engine that makes fueling at the jobsite more convenient. The diesel engine provides engine power of 3.2 kW (4.3 hp) and also excels in higher altitudes.



# OPTIONAL EQUIPMENT

BRINGING FLEXIBILITY FROM ONE JOBSITE TO THE NEXT

Quick-change options enhance versatility and ensure the machines are precisely matched for the jobsite. The options include a rubber mat for working on paving stones and a water sprinkling system for asphalt applications.

## OPTIONS

	APF 10/33	APF 12 / 40	APF 12 / 50	APF 15/40	APF 15/50	APF 20/50
RUBBER MAT	-	√	√	√	√	√
TRANSPORT WHEELS	-	√	√	√	√	√
WATER SPRINKLING SYSTEM	5 l (1.3 U.S. gal)	10 l (2.6 U.S. gal)	10 l (2.6 U.S. gal)	12 l (3.1 U.S. gal)	12 l (3.1 U.S. gal)	12 l (3.1 U.S. gal)
HOUR METER	-	-	-	√	√	√

√ = Available / - = Not available



### WATER SPRINKLING SYSTEM

The tank and sprinkler are combined into a single unit that can be added or removed without any tools. Not even a single screw needs to be adjusted. The sprinklers provide comprehensive surface coverage and can be activated by simply turning a switch. The 10-litre (2.6 U.S. gal) tanks extend intervals between fillings.



### PERMANENTLY INSTALLED TRANSPORT WHEELS

The transport wheels can be dropped with a foot release, preventing fingers from being pinched and reducing stress on the operator's back. The high quality wheels are durable and enable quick and easy transport around the jobsite.



### HOUR METER

The plates can be fitted with hour meters to help monitor maintenance needs.



### TOOLLESS MOUNTABLE RUBBER MAT

This optional mat can be mounted in a few seconds, preparing the machine for work on paving stones and protecting the stones' edges from cracking. Installation is extremely easy: The mat wraps around the foot and is secured with two hooks.



# SPECIFICATIONS

## APF FORWARD MOVING VIBRATORY PLATES

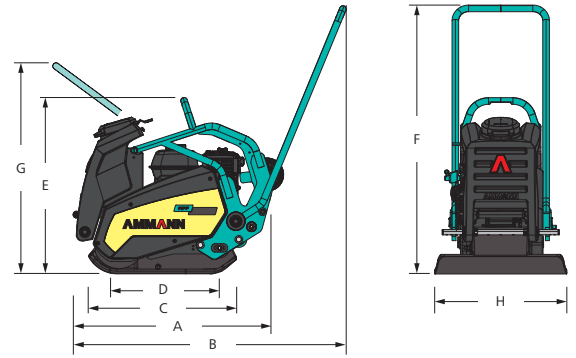

### DIMENSIONS & WEIGHTS

	APF 10/33 Honda	APF 12/40 Honda	APF 12/50 Honda	APF 15/40 Honda	APF 15/40 Vanguard	APF 15/50 Honda	APF 15/50 Vanguard	APF 20/50 Honda	APF 20/50 Vanguard	APF 20/50 Hatz
MACHINE WEIGHT	54 kg (119 lb)	69 kg (152 lb)	72 kg (159 lb)	80 kg (176 lb)	84 kg (185 lb)	84 kg (185 lb)	88 kg (194 lb)	88 kg (194 lb)	88 kg (194 lb)	106 kg (234 lb)
WITH OPT. SPRINKLER & WHEELS	-	76 kg (168 lb)	79 kg (174 lb)	89 kg (195 lb)	93 kg (205 lb)	93 kg (205 lb)	97 kg (214 lb)	97 kg (214 lb)	97 kg (214 lb)	115 kg (254 lb)
A MACHINE LENGTH	655 mm (25.8 in)	621 mm (24.4 in)	621 mm (24.4 in)	700 mm (27.6 in)	700 mm (27.6 in)	700 mm (27.6 in)	700 mm (27.6 in)	700 mm (27.6 in)	700 mm (27.6 in)	700 mm (27.6 in)
B WITH HANDLE	1130 mm (44.5 in)	1040 mm (40.9 in)	1040 mm (40.9 in)	1020 mm (40.2 in)	1020 mm (40.2 in)	1020 mm (40.2 in)	1020 mm (40.2 in)	1020 mm (40.2 in)	1020 mm (40.2 in)	1020 mm (40.2 in)
C BASE PLATE LENGTH	495 mm (19.5 in)	540 mm (21.3 in)	540 mm (21.3 in)	559 mm (22 in)	559 mm (22 in)	559 mm (22 in)	559 mm (22 in)	559 mm (22 in)	559 mm (22 in)	559 mm (22 in)
D GROUND CONTACT LENGTH	341 mm (13.4 in)	371 mm (14.6 in)	371 mm (14.6 in)	352 mm (13.9 in)	352 mm (13.9 in)	352 mm (13.9 in)	352 mm (13.9 in)	352 mm (13.9 in)	352 mm (13.9 in)	352 mm (13.9 in)
E MACHINE HEIGHT	507 mm (20 in)	514 mm (20.2 in)	514 mm (20.2 in)	667 mm (26.3 in)	667 mm (26.3 in)	667 mm (26.3 in)	667 mm (26.3 in)	667 mm (26.3 in)	667 mm (26.3 in)	674 mm (26.5 in)
F WITH HANDLE (WORK)	920 mm (36.2 in)	1000 mm (39.4 in)	1000 mm (39.4 in)	976 mm (38.4 in)	976 mm (38.4 in)	976 mm (38.4 in)	976 mm (38.4 in)	976 mm (38.4 in)	976 mm (38.4 in)	976 mm (38.4 in)
G WITH HANDLE (TRANSPORT)	1100 mm (43.3 in)	640 mm (25.2 in)	640 mm (25.2 in)	736 mm (29 in)	960 mm (37.8 in)	736 mm (29 in)	960 mm (37.8 in)	736 mm (29 in)	960 mm (37.8 in)	736 mm (29 in)
H MACHINE WIDTH	330 mm (13 in)	400 mm (15.7 in)	500 mm (19.7 in)	400 mm (15.7 in)	400 mm (15.7 in)	500 mm (19.7 in)	500 mm (19.7 in)	500 mm (19.7 in)	500 mm (19.7 in)	500 mm (19.7 in)

### ENGINE

ENGINE	GX 120	GX 120	GX 120	GX 120	Vanguard 160	GX 120	Vanguard 160	GX 160	Vanguard 160	1B20
FUEL	Petrol	Petrol	Petrol	Petrol	Petrol	Petrol	Petrol	Petrol	Petrol	Diesel
ENGINE OUTPUT	2.6 kW (3.5 HP)	2.6 kW (3.5 HP)	2.6 kW (3.5 HP)	2.6 kW (3.5 HP)	3.7 kW (5 HP)	2.6 kW (3.5 HP)	3.7 kW (5 HP)	3.4 kW (4.6 HP)	3.7 kW (5 HP)	3.2 kW (4.3 HP)
AT RPM	3600	3600	3600	3600	3600	3600	3600	3250	3250	3250

### COMPACTION FORCES

MAX. VIBRATION FREQUENCY	100 Hz (6000 vpm)	98 Hz (5880 vpm)	98 Hz (5880 vpm)	100 Hz (6000 vpm)	100 Hz (6000 vpm)	100 Hz (6000 vpm)	100 Hz (6000 vpm)	90 Hz (5400 vpm)	90 Hz (5400 vpm)	90 Hz (5400 vpm)
MAX. CENTRIFUGAL FORCE	10.5 kN (2360 lbf)	12 kN (2698 lbf)	12 kN (2698 lbf)	15 kN (3372 lbf)	15 kN (3372 lbf)	15 kN (3372 lbf)	15 kN (3372 lbf)	18 kN (4047 lbf)	18 kN (4047 lbf)	18 kN (4047 lbf)
SURFACE CAPACITY	436 m <sup>2</sup> /h (4689 ft <sup>2</sup> /h)	480 m <sup>2</sup> /h (5167 ft <sup>2</sup> /h)	600 m <sup>2</sup> /h (6458 ft <sup>2</sup> /h)	648 m <sup>2</sup> /h (6975 ft <sup>2</sup> /h)	648 m <sup>2</sup> /h (6975 ft <sup>2</sup> /h)	720 m <sup>2</sup> /h (7750 ft <sup>2</sup> /h)	720 m <sup>2</sup> /h (7750 ft <sup>2</sup> /h)	930 m <sup>2</sup> /h (10010 ft <sup>2</sup> /h)	930 m <sup>2</sup> /h (10010 ft <sup>2</sup> /h)	990 m <sup>2</sup> /h (10656 ft <sup>2</sup> /h)
SPEC. SURFACE PRESSURE	9.3 N/cm <sup>2</sup> (13.5 psi)	8.1 N/cm <sup>2</sup> (11.7 psi)	6.5 N/cm <sup>2</sup> (9.4 psi)	10.7 N/cm <sup>2</sup> (15.5 psi)	10.7 N/cm <sup>2</sup> (15.5 psi)	8.5 N/cm <sup>2</sup> (12.4 psi)	8.5 N/cm <sup>2</sup> (12.4 psi)	11.4 N/cm <sup>2</sup> (16.5 psi)	11.4 N/cm <sup>2</sup> (16.5 psi)	11.4 N/cm <sup>2</sup> (16.5 psi)

### MISCELLANEOUS

HAND-ARM VIBRATION ON HANDLE	11 m/s <sup>2</sup>	3.0 m/s <sup>2</sup>	3.0 m/s <sup>2</sup>	<2.5 m/s <sup>2</sup>	<2.5 m/s <sup>2</sup>	<2.5 m/s <sup>2</sup>	<2.5 m/s <sup>2</sup>	3.1 m/s <sup>2</sup>	3.1 m/s <sup>2</sup>	<2.5 m/s <sup>2</sup>
SPEED	0–22 m/min (0.8 mph)	0–20 m/min (0.7 mph)	0–20 m/min (0.7 mph)	0–27 m/min (1 mph)	0–27 m/min (1 mph)	0–24 m/min (0.9 mph)	0–24 m/min (0.9 mph)	0–31 m/min (1.2 mph)	0–31 m/min (1.2 mph)	0–33 m/min (1.2 mph)
GRADEABILITY	30%	30%	30%	30%	30%	30%	30%	30%	30%	30%
MAX. INCLINE, ALL SIDES	20°	20°	20°	20°	20°	20°	20°	20°	20°	20°

# SERVICE

## A NETWORK TO SUPPORT YOU

No matter where you are, Ammann-trained technicians and parts are nearby. Ammann dealers provide well-trained service technicians who can help you, whether it's an emergency or time for preventive maintenance. The vast Ammann network ensures there is a nearby technician who understands your language and your technical needs. Parts availability and ease of ordering are always Ammann priorities.

### HOTLINE SUPPORT

Ammann experts are ready to answer your technical questions 24 hours a day, seven days a week. The hotline team is highly trained and experienced. Representatives can talk you through the challenges – in various languages – to help keep your machine productive.

### SERVICE APP

The service app for Ammann machines impresses machine operators who are already benefiting from the advantages of the free application. The easy-to-use app provides machine operators working on site quick and uncomplicated access to machine documentation.

### SERVICE VIDEOS

Sometimes a video tells the story best. That's why you'll find a variety of service videos that walk you through service and maintenance processes.

### QR CODE

Many maintenance kits feature QR codes that link to videos with helpful demonstrations that walk you or your technician through the process. The videos tell the story without dialogue so customers anywhere in the world can understand.



APPLE STORE



ANDROID STORE

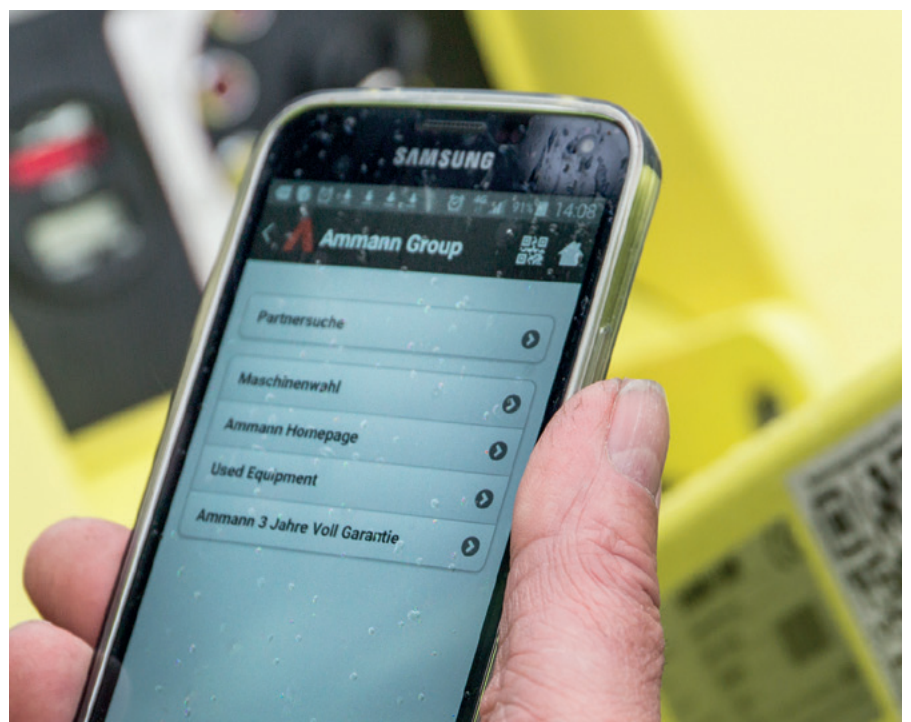





# DELIVERING THE DATA THAT MATTERS

## SERVICELINK

**Ammann ServiceLink is a digital data management tool that provides customers with the information they want the most: machine location, battery status and hours. Data transfer is automatic thanks to new hardware, and access to the information is only a click away.**

Manage your equipment – anytime, anywhere – with Ammann ServiceLink. This comprehensive fleet system provides key data for light compaction equipment, heavy compaction machines and asphalt pavers. You can choose which machines to track.

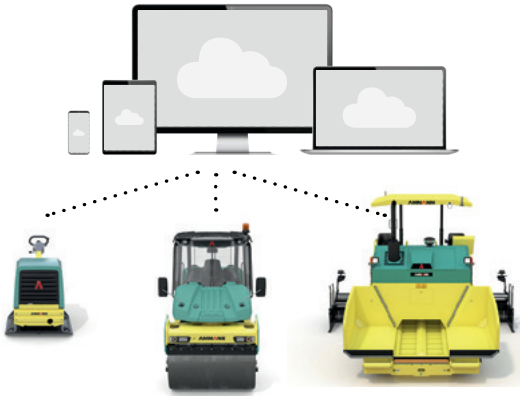

### HIGHLIGHTS

- Supplies machine location, operating hours, battery status
- Requires no subscription fees for Light Equipment
- Provides one-click access to data
- Reliably transmits data from machines, no matter where they are
- Streamlines fleet upgrades (retrofit option)
- Easy to install

## DOWNLOAD THE MOBILE APP OR USE THE DESKTOP APPLICATION

- ServiceLink Mobile App  
Manage your equipment – anytime and anywhere.
- ServiceLink Web Portal  
Organize and manage multiple construction sites in the workplace.



App Store



Google Play

Go to [MyAmmann.com](http://MyAmmann.com) for Ammann ServiceLink Web Portal

# TRAINING

## ENHANCE YOUR PERFORMANCE

If Ammann machine training was summarised in a single word, it might well be “comprehensive.” The training includes multiple expertise levels and modules to benefit all skill levels.

### TRAINING WORLDWIDE

Ammann product and application experts are ready to provide the training you need, no matter where you are. The global nature of Ammann ensures an expert is always near you – ready to offer instruction that ranges from the basics to the specifics relevant to your geographic area. The training can take place at an Ammann facility, your business – or even on a jobsite.

### KEY TEACHING THEMES CONNECT ALL EFFORTS, NO MATTER WHERE THEY OCCUR

**A good balance.** Training often combines a traditional classroom setting with hands-on machine experience. Ammann application experts also can offer instruction on your jobsite.

Training typically includes students from other industry businesses. Participants say conversations with their peers – and learning how they overcome challenges – are other key benefits.

**Learn in your language.** Lessons are taught in many languages, ensuring your team understands key terms and lessons and makes the most of your training investment.





# SPARE PARTS

You can only earn money when your equipment is working. That's why Ammann does everything possible to ensure you have the parts where and when you need them. Those efforts include easy online ordering to avoid confusion and enable tracking, and efficient logistics and availability to help parts reach you quickly.

## WEARING KITS

Some machines handle abrasive materials in demanding applications. While wear is inevitable, downtime can be limited. Wearing kits make replacement of these parts efficient and cost-effective. All the necessary parts – big and small – are in a single box to keep you organised and efficient and to ensure the machines are quickly back up and running.

## EMERGENCY KITS

Emergency kits prevent little frustrations from becoming bigger issues that can shut down a machine and even a jobsite. These kits include parts such as switches, fuses and valve coils that are simple and fast to change yet still can cause significant problems if not operating properly. The kits easily fit in the trunk or bed of a vehicle so they're on hand when needed. A crew-member with a bit of technical knowledge can handle this work on the jobsite. These repairs take 2 hours or less.



## MAINTENANCE KITS

Preventive maintenance is crucial to efficient operation and service life of machines. The easier the maintenance, the more likely it is to be completed. Maintenance kits make the upkeep simple. Parts associated with a particular maintenance process are in a single box with a single part number.

## BROCHURE WITH ALL KITS

We have a prospect with all kits, and their part numbers are available for you. Just contact your parts consultant and have a digital or hardcopy sent to you.



For additional product information  
and services please visit:  
**[www.ammann.com](http://www.ammann.com)**

