



APF 12/50

FORWARD MOVING VIBRATORY PLATE

A STRONG ALL-AROUND PERFORMER

A powerful, efficient petrol Honda engine brings optimal machine performance to this plate compactor. The engine is also environmentally friendly, thanks to exceptional fuel consumption, minimal maintenance needs and low sound levels. The machine works well in many applications and is commonly utilised on small soil and asphalt jobsites. A 10-litre water tank, large for this particular machine class, is an option appreciated by many contractors.

EFFECTIVE COMPACTION TOOL

- A powerful Honda petrol engine is the force behind the exciter unit and the foundation for the plate's exceptional compaction performance.
- A centrifugal clutch and V belt effectively transfer power to the exciter system that delivers the powerful forward movement.
- An optional water sprinkling system enables work on bituminous surfaces and greatly enhances the compactor's versatility.

LIMITED MAINTENANCE

- A well-protected, robust centrifugal clutch with wear-resistant V belt provides long machine life.

- An extended-life exciter unit stretches service intervals and reduces maintenance costs.
- The base plate utilises wear-resistant materials and a self-cleaning design to lengthen the unit's life.

IMPROVED GUIDE HANDLE

- The vibration-isolated guide handle reduces operator stress, permitting longer working shifts while minimising the risk of injury.
- The handle can be folded flush with the machine or even removed, enhancing manoeuvrability in tight spaces and making transport easy.

APPLICATIONS

- Compaction in confined areas
- Earthwork
- Asphalt and paving applications
- Light to medium patchwork
- Pipeline and trench construction
- Landscaping and gardening

AMMANN

TECHNICAL SPECIFICATIONS
APF 12/50 FORWARD MOVING VIBRATORY PLATE

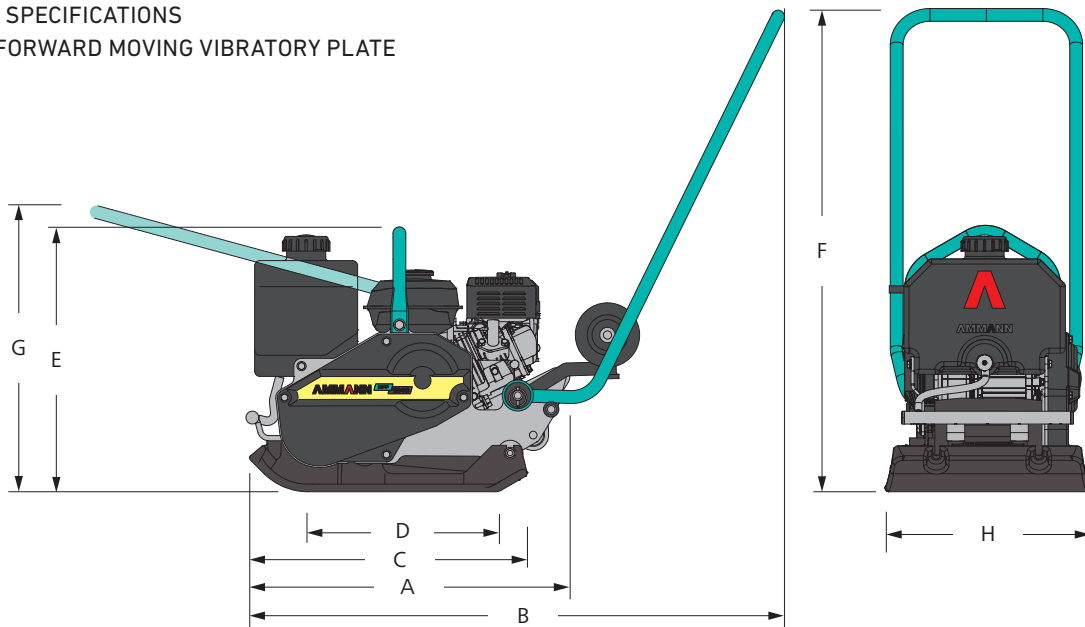

DIMENSIONS & WEIGHTS

MACHINE WEIGHT	72 kg (159 lb)
MACHINE WEIGHT (INCL. OPTIONAL SPRINKLER & WHEELS)	79 kg (174 lb)
A MACHINE LENGTH	621 mm (24.4 in)
B MACHINE LENGTH WITH HANDLE	1040 mm (40.9 in)
C BASE PLATE LENGTH	540 mm (21.3 in)
D GROUND CONTACT LENGTH	371 mm (14.6 in)
E MACHINE HEIGHT	514 mm (20.2 in)
F WITH HANDLE (WORK)	1000 mm (39.4 in)
G WITH HANDLE (TRANSPORT)	640 mm (25.2 in)
H MACHINE WIDTH	500 mm (19.7 in)

COMPACTION FORCES

MAX. VIBRATION FREQUENCY	98 Hz (5880 vpm)
MAX. CENTRIFUGAL FORCE	12 kN (2698 lbf)
WORKING SURFACE	600 m ² /h (6458 ft ² /h)
SPEC. SURFACE PRESSURE	6.5 N/cm ² (9.4 psi)

STANDARD EQUIPMENT

- Vibration-isolated guide handle
- Central lifting point
- Powerful and reliable petrol engine
- Service friendly exciter unit with expanded life expectancy
- Well protected, sturdy centrifugal clutch and V-Belt

ENGINE

ENGINE	Honda GX 120
FUEL	Petrol
ENGINE OUTPUT	2.6 kW (3.5 HP)
AT RPM	3600

MISCELLANEOUS

HAND-ARM VIBRATION ON HANDLE	3.0 m/s ²
SPEED	0–20 m/min (65.6 ft/min)
GRADEABILITY	30%
MAX. INCLINE TO ALL SIDES	20°

OPTIONS

RUBBER MAT	x
TRANSPORT WHEELS	x
WATER SPRINKLER SYSTEM	10 l (2.6 U.S. gal)

OPTIONAL EQUIPMENT

- Transport wheels
- Rubber (vulcolan) mat for application on paving stones
- Corrosion-free water tank and sprinkling system
- 3 year extended warranty program